

Instruction Manual



P7350SMA 5 GHz Differential Probe 071-1264-00

Warning

The servicing instructions are for use by qualified personnel only. To avoid personal injury, do not perform any servicing unless you are qualified to do so. Refer to all safety summaries prior to performing service.

www.tektronix.com

Copyright © Tektronix, Inc. All rights reserved.

Tektronix products are covered by U.S. and foreign patents, issued and pending. Information in this publication supercedes that in all previously published material. Specifications and price change privileges reserved.

Tektronix, Inc., P.O. Box 500, Beaverton, OR 97077

TEKTRONIX, TEK, and TekConnect are registered trademarks of Tektronix, Inc.

WARRANTY

Tektronix warrants that the products that it manufactures and sells will be free from defects in materials and workmanship for a period of one (1) year from the date of shipment. If a product proves defective during this warranty period, Tektronix, at its option, either will repair the defective product without charge for parts and labor, or will provide a replacement in exchange for the defective product.

In order to obtain service under this warranty, Customer must notify Tektronix of the defect before the expiration of the warranty period and make suitable arrangements for the performance of service. Customer shall be responsible for packaging and shipping the defective product to the service center designated by Tektronix, with shipping charges prepaid. Tektronix shall pay for the return of the product to Customer if the shipment is to a location within the country in which the Tektronix service center is located. Customer shall be responsible for paying all shipping charges, duties, taxes, and any other charges for products returned to any other locations.

This warranty shall not apply to any defect, failure or damage caused by improper use or improper or inadequate maintenance and care. Tektronix shall not be obligated to furnish service under this warranty a) to repair damage resulting from attempts by personnel other than Tektronix representatives to install, repair or service the product; b) to repair damage resulting from improper use or connection to incompatible equipment; c) to repair any damage or malfunction caused by the use of non-Tektronix supplies; or d) to service a product that has been modified or integrated with other products when the effect of such modification or integration increases the time or difficulty of servicing the product.

THIS WARRANTY IS GIVEN BY TEKTRONIX IN LIEU OF ANY OTHER WARRANTIES, EXPRESS OR IMPLIED. TEKTRONIX AND ITS VENDORS DISCLAIM ANY IMPLIED WARRANTIES OF MERCHANTABILITY OR FITNESS FOR A PARTICULAR PURPOSE. TEKTRONIX' RESPONSIBILITY TO REPAIR OR REPLACE DEFECTIVE PRODUCTS IS THE SOLE AND EXCLUSIVE REMEDY PROVIDED TO THE CUSTOMER FOR BREACH OF THIS WARRANTY. TEKTRONIX AND ITS VENDORS WILL NOT BE LIABLE FOR ANY INDIRECT, SPECIAL, INCIDENTAL, OR CONSEQUENTIAL DAMAGES IRRESPECTIVE OF WHETHER TEKTRONIX OR THE VENDOR HAS ADVANCE NOTICE OF THE POSSIBILITY OF SUCH DAMAGES.



Preface

This is the Instruction Manual for the P7350SMA differential probe. This manual provides operating information, specifications, performance verification procedures, and a replaceable parts list.

Contacting Tektronix

Phone	1-800-833-9200*
Address	Tektronix, Inc. Department or name (if known) 14200 SW Karl Braun Drive P.O. Box 500 Beaverton, OR 97077 USA
Web site	www.tektronix.com
Sales support	1-800-833-9200, select option 1*
Service support	1-800-833-9200, select option 2*
Technical support	Email: techsupport@tektronix.com 1-800-833-9200, select option 3* 6:00 a.m. - 5:00 p.m. Pacific time

* **This phone number is toll free in North America. After office hours, please leave a voice mail message. Outside North America, contact a Tektronix sales office or distributor; see the Tektronix web site for a list of offices.**

Table of Contents

Getting Started	1
Features and Standard Accessories	2
Optional Accessories	5
Options	6
P7350SMA Probe Head	7
TekConnect Interface	9
Functional Check	10
Signal Check	10
DC Termination Check	11
Probe Calibration	13
Probe Applications	14
Operating Basics	15
Input Circuitry	15
Probe Termination Network	16
Differential Signals	16
Single-Ended Signals	17
Matched-Delay Cables	19
DC Termination Voltage Input	21
Calculating DC Termination Resistor Power	22
DC Voltage Applied to SMA Inputs with the DC Termination Voltage Input Grounded	23
Complementary Input Signal with the DC Termination Voltage Input Open	24
Complementary Input Signal with the DC Termination Voltage Input Shorted (Grounded)	26
Equations and Definitions	28
Internal Probe Amplifier	29
Maximum Input Voltage	29
Common-Mode Signal Range	29
Differential-Mode Signal Range	29
Differential Offset Range	30
Common-Mode Rejection	31
Input Impedance and Probe Loading	31
Checking the Skew Between Inputs	32
Adjusting Cable Skew	33
Deskewing Probes	35

Reference	39
Differential Measurements	39
Common-Mode Rejection Ratio	40
Extending the Input Connections	41
InfiniBand	42
Appendix A: Specifications	43
Warranted Characteristics	43
Typical Characteristics	44
Nominal Characteristics	48
Mechanical Characteristics	48
Appendix B: Performance Verification	51
Equipment Required	51
Special Adapters Required	53
TekConnect-to-SMA Adapter	53
TekConnect Interface Calibration Adapter	54
Equipment Setup	55
Input Resistance	56
Output Offset Zero	57
DC Gain Accuracy	58
Rise Time	60
Appendix C: Maintenance	67
Inspection and Cleaning	67
Replacement Parts	68
Preparation for Shipment	68
Appendix D: Replaceable Parts	69
Parts Ordering Information	69
Using the Replaceable Parts List	70
Item Names	70
Indentation System	70
Abbreviations	70

List of Figures

Figure 1: P7350SMA differential probe	1
Figure 2: Probe head connections	8
Figure 3: Connecting and disconnecting the probe	9
Figure 4: Probe signal check setup	10
Figure 5: Probe DC termination check	12
Figure 6: Typical probe applications and configurations	14
Figure 7: Simplified probe schematic	15
Figure 8: Single-ended drive	17
Figure 9: Resultant waveform from an unterminated input ...	18
Figure 10: Distorted pulse edge	20
Figure 11: Worst-case power dissipation example	23
Figure 12: Example of probe with DC input open	24
Figure 13: Example of probe with DC input shorted to ground	26
Figure 14: Probe amplifier and offset circuit	30
Figure 15: Typical probe input model	31
Figure 16: Checking skew between inputs	33
Figure 17: Using the phase adjuster	34
Figure 18: Deskewing two P7350SMA probes	36
Figure 19: Simplified model of a differential amplifier	39
Figure 20: InfiniBand signals	42
Figure 21: Typical common- and differential-mode gain plots	46
Figure 22: Typical differential input return loss	47
Figure 23: Typical differential-mode bandwidth	47
Figure 24: Probe head and compensation box dimensions ...	49
Figure 25: TekConnect-to-SMA Adapter	53
Figure 26: TekConnect Interface Calibration Adapter	54
Figure 27: Checking differential mode input resistance	56
Figure 28: Setup for the output offset zero test	57
Figure 29: DC Gain Accuracy setup	58
Figure 30: Reverse the power supply polarity on the probe inputs	59
Figure 31: Test system rise time setup	61
Figure 32: Setting the TDR parameters	62
Figure 33: Test system rise time setup with probe	64
Figure 34: Replaceable parts	71
Figure 35: Standard accessories	72
Figure 36: Optional accessories	74

Table of Contents



General Safety Summary

Review the following safety precautions to avoid injury and prevent damage to this product or any products connected to it. To avoid potential hazards, use this product only as specified.

To Avoid Fire or Personal Injury

Connect and Disconnect Properly. Connect the probe output to the measurement instrument before connecting the probe to the circuit under test. Disconnect the probe input from the circuit under test before disconnecting the probe from the measurement instrument.

Observe All Terminal Ratings. To avoid fire or shock hazard, observe all ratings and markings on the product. Consult the product manual for further ratings information before making connections to the product.

The common terminal is at ground potential. Do not connect the common terminal to elevated voltages.

Do Not Operate Without Covers. Do not operate this product with covers or panels removed.

Do Not Operate With Suspected Failures. If you suspect there is damage to this product, have it inspected by qualified service personnel.

Do Not Operate in Wet/Damp Conditions.

Do Not Operate in an Explosive Atmosphere.

Keep Product Surfaces Clean and Dry.

Safety Terms and Symbols

Terms in This Manual. These terms may appear in this manual:



WARNING. *Warning statements identify conditions or practices that could result in injury or loss of life.*



CAUTION. *Caution statements identify conditions or practices that could result in damage to this product or other property.*

Terms on the Product. These terms may appear on the product:

DANGER indicates an injury hazard immediately accessible as you read the marking.

WARNING indicates an injury hazard not immediately accessible as you read the marking.

CAUTION indicates a hazard to property including the product.

Symbols on the Product. These symbols may appear on the product:



CAUTION
Refer to Manual



Service Safety Summary

Only qualified personnel should perform service procedures. Read this *Service Safety Summary* and the *General Safety Summary* before performing any service procedures.

Do Not Service Alone. Do not perform internal service or adjustments of this product unless another person capable of rendering first aid and resuscitation is present.

Getting Started

The P7350SMA is a 5 GHz, active differential probe designed for Serial Data Analysis (SDA) compliance testing and other applications that use differential serial busses in a 50 Ω signaling environment. The SMA input connectors each terminate with an internal 50 Ω resistor. Banana plug terminals on the probe head provide inputs for a common-mode DC termination voltage. The probe incorporates the high-performance TekConnect interface to communicate with the host instrument.

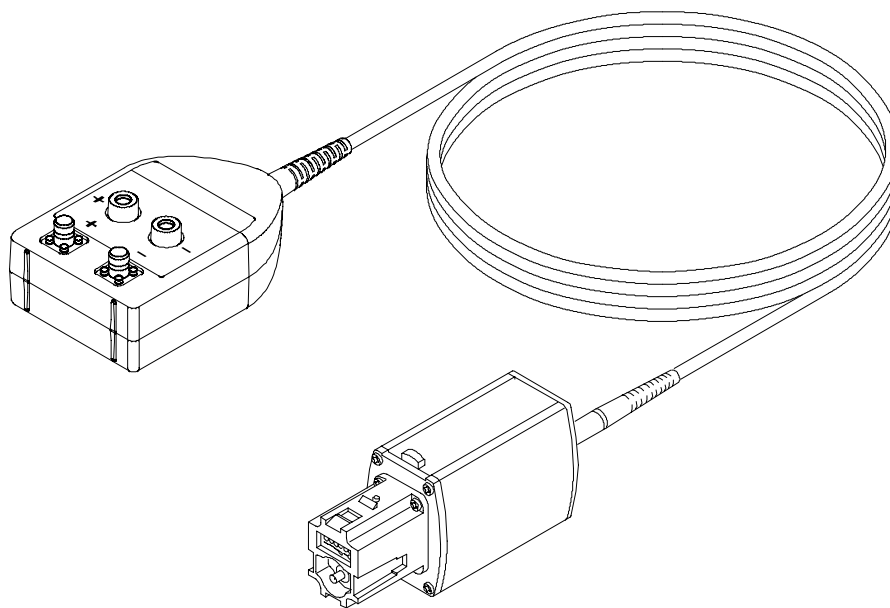

Figure 1: P7350SMA differential probe

The probe is shipped with 50 Ω termination caps connected to the SMA inputs. When you make single-ended measurements, leave one of the termination caps on the unused input to provide a clean, 50 Ω termination for the single-ended signal. When you are not using the probe, leave both of the termination caps connected to protect the SMA inputs from damage.

Features and Standard Accessories

Table 1 shows the features and standard accessories of the P7350SMA differential probe.

Table 1: P7350SMA features and standard accessories

Feature/Accessory	Description
	<p>TekConnect interface. The TekConnect interface provides a communication path between the probe and the oscilloscope. Contact pins provide power, signal, offset, and probe characteristic data transfer.</p> <p>The probe snaps into the oscilloscope when fully engaged. To remove, grasp the compensation box, press the latch button, and pull the probe out.</p> <p>For more information, see page 9.</p>
	<p>Input connections. The SMA terminals provide shielded, low-noise connections to your circuit. Differential or single-ended signals are buffered by the internal probe amplifier and are sent through the TekConnect interface to the oscilloscope.</p> <p>See <i>Operating Basics</i> on page 15 for more information.</p>
	<p>External DC termination voltage connections. The red and black banana jacks on the probe head provide a means for connecting an external DC voltage to the internal termination network, for drivers that require a DC termination voltage.</p> <p>You should use shielded test cables when connecting external DC voltages to these terminals. For example, use a coaxial BNC cable and a BNC-to-dual banana plug adapter.</p> <p><i>Caution: The internal termination resistors are rated for 500 mW. To prevent exceeding these limits, see page 22 for information on calculating power dissipation and other related topics.</i></p>

Table 1: P7350SMA features and standard accessories (Cont.)



Feature/Accessory	Description
	<p>Male SMA termination (2 ea). Protect the probe input circuitry by connecting the termination to the probe SMA input connector when the probe is not in use. When making single-ended measurements in a 50 Ω environment, use one of these terminations on the unused input.</p> <p>The probe is shipped with the terminations connected to the probe SMA inputs.</p> <p>Tektronix part number: 015-1022-01</p>
	<p>Dual SMA cables. These 12-in cables are bound together and have a skew of less than 10 ps. The cables provide matched signal paths from your circuit to the probe to ensure more accurate differential signal measurements.</p> <p>Tektronix part number: 174-4866-XX</p>
	<p>Dual banana shorting plug. Use the shorting plug when you are calibrating the probe, or when you need to bring the common-mode node of the termination network to ground.</p> <p>Tektronix part number: 012-1667-XX</p>
 <p>Markers</p>	<p>Cable marker bands (10 ea). Attach matching pairs of the marker bands onto the cable at both the head and compensation box of each probe. The marker bands allow you to quickly verify which instrument channel your probe is connected to when you are using multiple channels.</p> <p>Tektronix part number: 016-1886-XX (package of 10)</p>
	<p>SMA Female-to-BNC Male adapter. Use the adapter to connect the probe SMA inputs to BNC connections, such as the BNC calibration output connector on your oscilloscope.</p> <p>Tektronix part number: 015-0572-XX</p>

Table 1: P7350SMA features and standard accessories (Cont.)

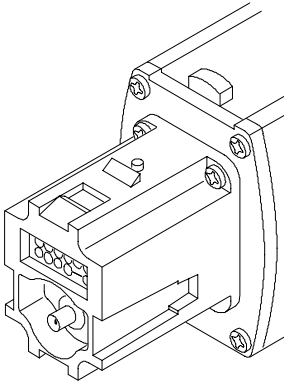
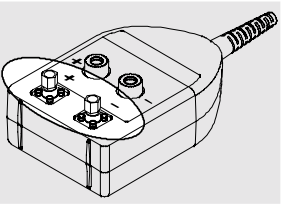
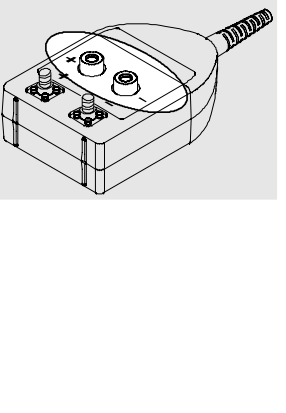
Feature/Accessory	Description
	<p>Antistatic wrist strap. When using the probe, always work at an antistatic work station and wear the antistatic wrist strap.</p> <p>Tektronix part number: 006-3415-XX</p>
	<p>Calibration certificate. A certificate of traceable calibration is provided with every instrument shipped.</p>
	<p>Instruction Manual. Provides instructions for operating and maintaining the P7350SMA differential probe.</p> <p>Tektronix part number: 071-1264-XX</p>

Optional Accessories

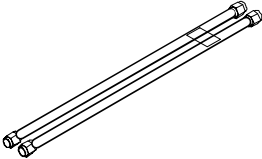
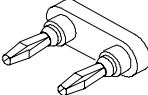
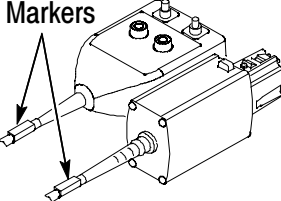
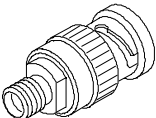
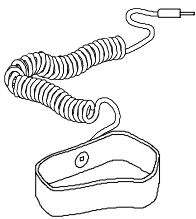
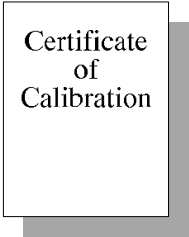
Table 2 shows the optional accessories that you can order for the P7350SMA differential probe.

Table 2: Optional accessories

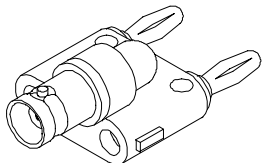
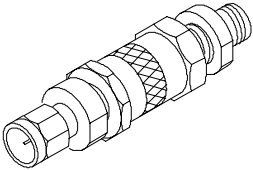
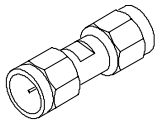
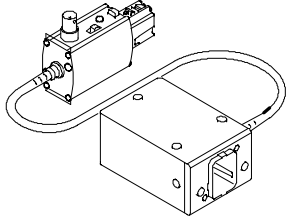
Accessory	Description
	<p>BNC-to-dual banana plug adapter. Use these adapters with BNC cables to provide a shielded path to the DC termination voltage terminals on the probe.</p> <p>Tektronix part number: 103-0090-XX</p>
	<p>Phase adjuster. Use two phase adjusters if you need to bring the skew between inputs to 1 ps or less when you use the matched-delay SMA cables to connect to your circuit.</p> <p>The matched-delay SMA cables that come with your probe have a ≤ 10 ps warranted skew at the cable ends.</p> <p>Tektronix part number: 015-0708-XX</p>
	<p>SMA Male-to-Male adapter. Use the adapter to connect the probe SMA inputs to other SMA female connections, such as those on your test fixture or sampling head. See Figure 24 on page 49 for SMA connector spacing dimensions.</p> <p>Tektronix part number: 015-1011-XX</p>
	<p>TekConnect interface calibration adapter. The calibration adapter is required when a performance verification or adjustment is done on the probe. It provides connectors and test points for internal probe measurements.</p> <p>Tektronix part number: 067-0422-XX</p>

Options

The following options are available when ordering the P7350SMA probe:

- Option D1-Calibration Data Report
- Option D3-Calibration Data Report, 3 years (with Option C3)
- Option C3-Calibration Service 3 years
- Option D5-Calibration Data Report, 5 years (with Option C5)
- Option C5-Calibration Service 5 years
- Option R3-Repair Service 3 years
- Option R5-Repair Service 5 years

P7350SMA Probe Head

The P7350SMA probe has two pairs of inputs, shown in Figure 2 on page 8:

- The SMA connectors provide a signal path through the internal 50 Ω termination network to the oscilloscope.

Use the matched-delay SMA cables that are supplied with the probe to connect the probe to your circuit.

You can mate the probe directly to your circuit if your connector layout matches those on the probe. See *Specifications* on page 43 for the dimensions, and use the optional SMA Male-to-Male adapters.

Leave the 50 Ω termination caps on the unused inputs.

- Banana jacks are provided for external DC termination voltages, which expand the measurement capabilities of your probe. The center-tap (common-mode node) of the internal 50 Ω termination network is connected to the red banana-jack terminal on the probe head. The black banana-jack terminal is connected to system ground.



CAUTION. *The input termination resistors have a thermal power rating of 0.5 W and are subject to damage if an excessive DC plus AC rms signal is applied. To prevent damaging the probe, see page 22 for instructions on calculating the termination resistor power.*

Generally, if you are taking differential measurements on complementary signals, you should leave the DC terminals open.

Short the DC terminals together with the banana-plug shorting strap when you are making lower speed, single-ended measurements. A low impedance connection from the DC termination voltage input to ground is required when measuring single-ended signals with frequency content below 7 MHz.

If the signal driver requires you to sink or source DC current, use the DC terminals to bring in an external termination voltage.

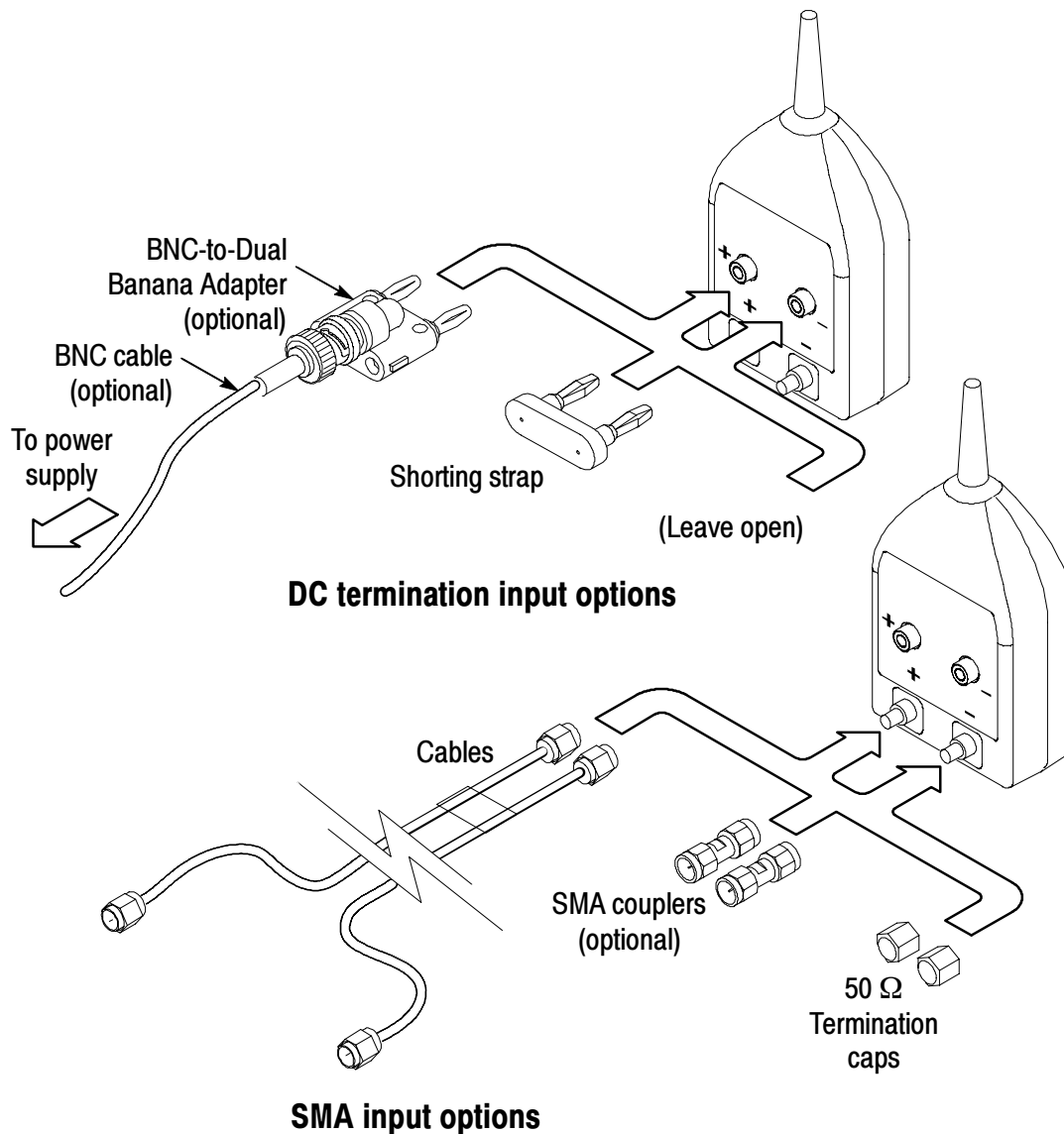

Figure 2: Probe head connections

Mounting holes are provided on the bottom of the probe head to secure the probe to your test fixture or device under test. See *Specifications* on page 43 for the mounting hole dimensions and locations.

TekConnect Interface

The P7350SMA probe is powered through a TekConnect interface between the probe compensation box and the host instrument. The TekConnect interface provides a communication path through contact pins on the host instrument. Power, signal, offset, and probe characteristic data transfer through the interface.

When the probe is connected, the host instrument reads EEPROM information from the probe, identifying the device and allowing the appropriate power supplies to be turned on. The preamp inputs on the host instrument are ESD protected by remaining grounded until a valid TekConnect device is detected.

The TekConnect interface features a spring-loaded latch that provides audible and tactile confirmation that a reliable connection has been made to the host instrument. Slide the probe into the TekConnect receptacle on the host instrument. The probe snaps into the receptacle when fully engaged. See Figure 3.

To release the probe from the host instrument, grasp the compensation box, press the latch button, and pull out the probe.

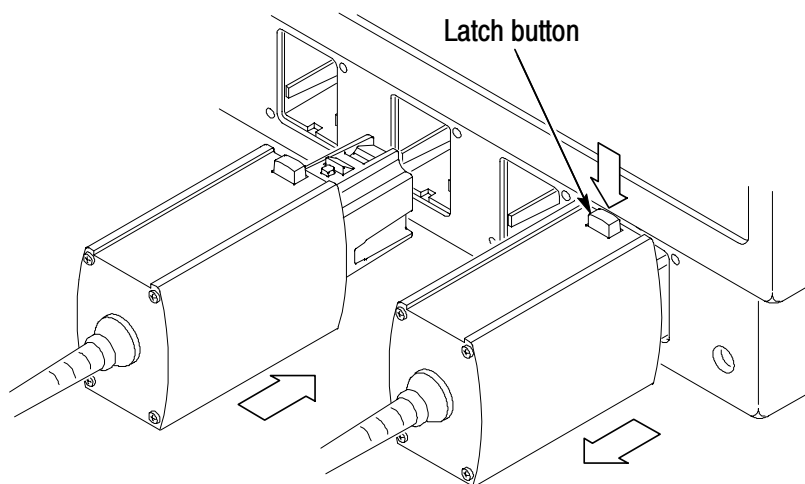

Figure 3: Connecting and disconnecting the probe

Functional Check

Before using your probe, you should perform a functional check on your probe. Figure 4 illustrates a typical setup using the PROBE COMPENSATION output on the front panel of the oscilloscope.

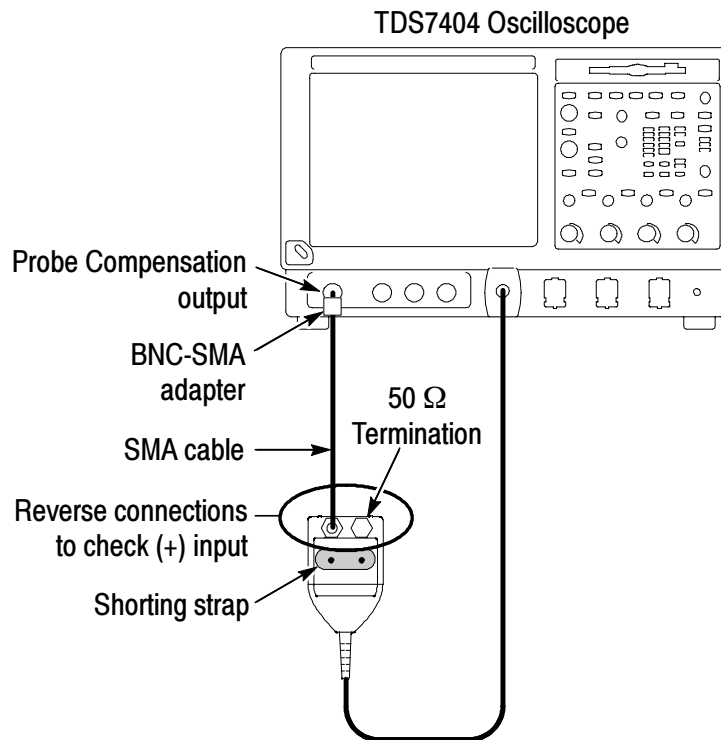

Figure 4: Probe signal check setup

Signal Check

1. Connect the probe to one of the oscilloscope channels, and set the oscilloscope to display the channel. Allow the probe and oscilloscope to warm up for at least 20 minutes.
2. Connect the BNC-SMA adapter (included with your probe) to the PROBE COMPENSATION connector on the oscilloscope.
3. Connect an SMA cable between the adapter and the (-) SMA probe input. (You can use one cable of the matched-delay cable set included with your probe.)

4. Connect a 50 Ω SMA termination to the (+) SMA probe input.
5. Connect a shorting strap or test lead between the two DC termination inputs on the probe. (Due to the low repetition rate of the oscilloscope calibration signal, the shorting strap is needed to provide a broadband 50 Ω termination to ground.)
6. Press Autoset or adjust the oscilloscope to display a stable calibration waveform. A stable square wave indicates that the probe input that you are using is functional. Signal amplitude is dependent on oscilloscope model.
7. Reverse the probe SMA connections, and repeat step 6 to check the (+) input.

DC Termination Check

8. Disconnect the SMA cable from the (+) input of the probe. Leave the 50 Ω SMA termination connected to the (-) probe input.
9. Disconnect the shorting strap or test lead from the two DC termination inputs on the probe.
10. Turn on the power supply, and set it to 0 volts.
11. Connect the power supply to the probe with a BNC cable and two BNC-to-dual banana adapters. The test setup is shown in Figure 5 on page 12.

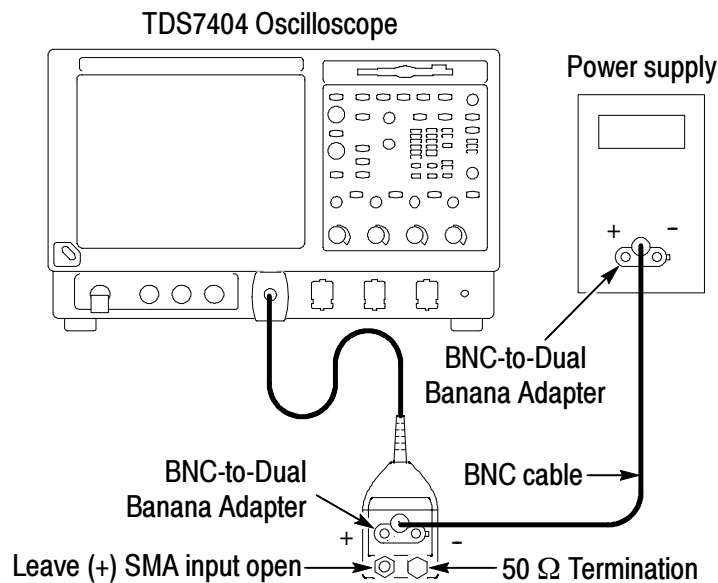

Figure 5: Probe DC termination check

12. Press Autoset or adjust the oscilloscope to center the trace.
13. Set the oscilloscope volts/division to 200 mV.
14. Adjust the power supply between approximately +1.0 V and -1.0 V. The trace of a functional probe will vary between approximately +0.5 V and -0.5 V (about 5 divisions).
15. Move the 50 Ω SMA termination to the (+) SMA probe input.
16. Adjust the power supply between approximately +1.0 V and -1.0 V. The trace of a functional probe will vary inversely (between approximately -0.5 V and +0.5 V, about 5 divisions).

This completes the functional check of the probe. If your instrument supports probe calibration routines, now is a good time to perform them. See *Probe Calibration* on page 13 for instructions.

Probe Calibration

After you perform a functional check of the probe, you should run a probe calibration routine. The Calibration Status of the instrument Signal Path Compensation test must be **pass** for the probe calibration routine to run:

1. From the Utilities menu, select Instrument Calibration.
2. In the Calibration box, check that the Status field is **pass**. If it is not, disconnect all probes and signal sources from the oscilloscope, and run the Signal Path Compensation routine.

When the Signal Path Compensation test status is **pass**, run the probe calibration routine:

3. Connect the probe to one of the oscilloscope channels, and set the oscilloscope to display the channel. Allow the probe to warm up for 20 minutes.
4. Connect the SMA cable from the PROBE COMPENSATION connector on the oscilloscope to the (+) SMA probe input. Leave a 50 Ω termination on the (-) SMA probe input. The test setup is shown in Figure 4 on page 10, except the SMA inputs are reversed.
5. Connect the shorting strap or test lead to the two DC termination inputs on the probe. The DC termination voltage banana plug input must be shorted to the banana plug ground input because the single-ended Probe Compensation signal is a variable DC voltage.
6. From the Vertical menu, select Probe Cal.
7. Press or click Calibrate probe.

After the probe passes the functional checks and probe calibration routine, you can use the probe in your measurement system.

You should read the *Operating Basics* section to familiarize yourself with related probe functions and capabilities. Important topics include the *Probe Termination Network*, *Matched-Delay Cables*, and the *DC Termination Voltage Terminals*.

Probe Applications

You can use the probe to make both single-ended and differential measurements. Figure 6 illustrates some typical probe applications and configurations. See *Operating Basics* for details on using the probe.

Differential with DC terminals open

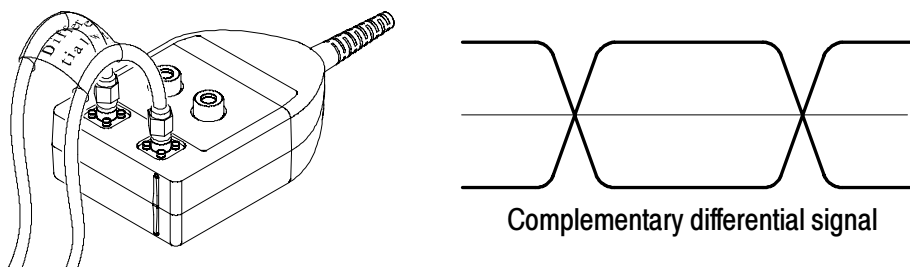

Differential with external DC bias applied to terminals

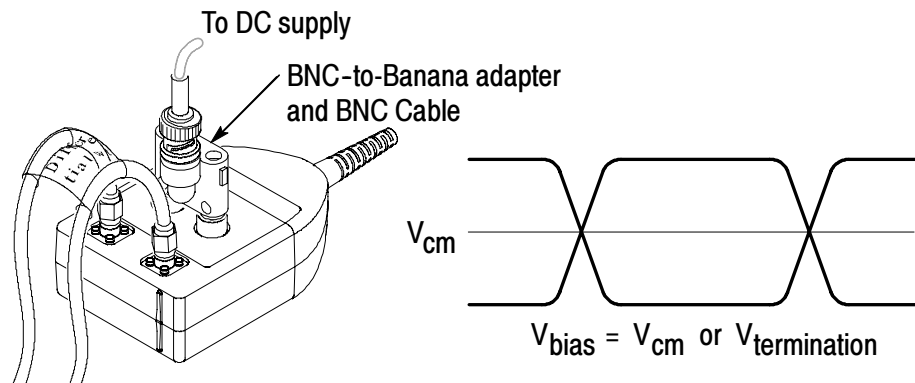

Single-ended with DC terminals shorted

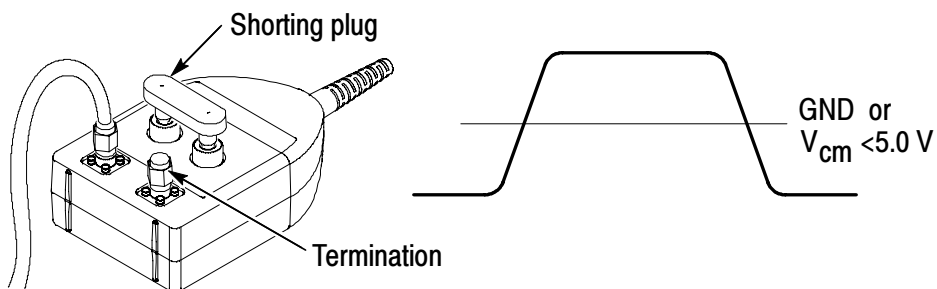

Figure 6: Typical probe applications and configurations

Operating Basics

This section discusses the probe architecture and operating considerations. For more detailed information about differential measurements and common-mode rejection ratio (CMRR), see the *Reference* section on page 39.

Input Circuitry

The SMA inputs and probe termination network provide a high frequency, $50\ \Omega$ signal path to the internal probe amplifier. The use of SMA-female connectors provides a reliable, repeatable attachment method for input signals. The symmetry of the input termination network is designed to reduce skew and maximize CMRR.

The DC input to the probe termination network provides flexibility for input signals that have a significant DC component. A simplified schematic of the probe is shown in Figure 7.

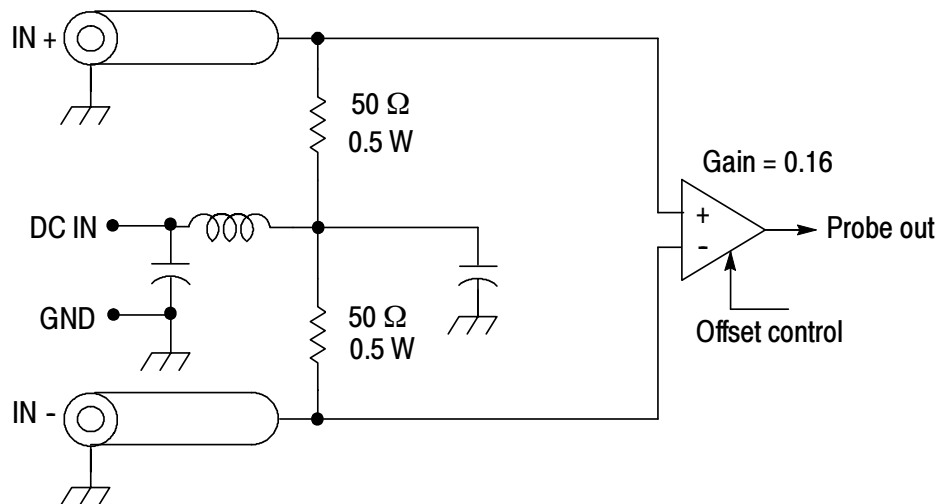

Figure 7: Simplified probe schematic

Probe Termination Network

The P7350SMA probe can be used to make both differential and common mode measurements, taking into consideration the characteristics of the probe termination network. A discussion of the probe termination network follows.

Differential Signals

For a differential input signal with a purely complementary drive (like the differential signals shown in Figure 6 on page 14), the AC components of the signal effectively terminate at the common mode node of the probe termination network. Due to symmetry of the termination network, the common mode node between the 50 Ω termination resistors acts like a virtual ground for broadband signals with a complementary drive and matched source impedance.

Any DC common mode component of the input signal will result in a DC voltage at the common mode node of the termination network, which will generally not be seen in the probe output display due to the large DC CMRR of the probe amplifier. The DC input connection to the probe termination network can be set using an external DC power supply. The DC input can be set to match the input common mode node voltage or to some other value if the input signal drive circuitry requires a DC termination voltage for correct operation.

Imbalance in either the signal drive or the signal connection path generates an AC common mode component in the differential input signal. The probe termination network provides capacitance at the common mode node to terminate high-frequency common mode signals. The common mode capacitance of approximately 0.022 μF holds the common mode node impedance below one ohm, down to a breakpoint frequency of about 7 MHz.

If the DC input connector of the probe is also driven from a low impedance DC source, this common mode node impedance can be kept small all the way down to DC.

The AC common mode component of the input signal will also be significantly reduced in the displayed probe output signal due to the AC CMRR of the probe amplifier, which varies with frequency. See Figure 21 on page 46.

Single-Ended Signals

For a single-ended input signal, or where common mode measurements are required for each side of a differential input signal, the single-ended input should be connected to the IN+ connector of the probe. For single-ended measurements, the unused IN- connector of the probe should be terminated with an impedance that matches the single-ended source impedance. In the case of high-speed serial data signals, for which the P7350SMA probe has been optimized, the source impedance will generally be $50\ \Omega$, so a $50\ \Omega$ termination resistor should be attached to the unused IN- connector.

With a $50\ \Omega$ single-ended drive signal on the IN+ connector, and a $50\ \Omega$ termination on the IN- connector, the probe termination network provides a broadband termination to the single-ended input and has flat pulse response, even with the probe DC input port not connected. This topology, shown in Figure 8, looks similar to the previous differential input configuration, but with one side of the complementary drive signal set to zero. The resulting AC output signal should have one half the amplitude of a similar differential measurement. This single-ended topology also results in a measurable DC common mode component, since the DC common mode signal is converted to a differential mode signal by the input termination network topology.

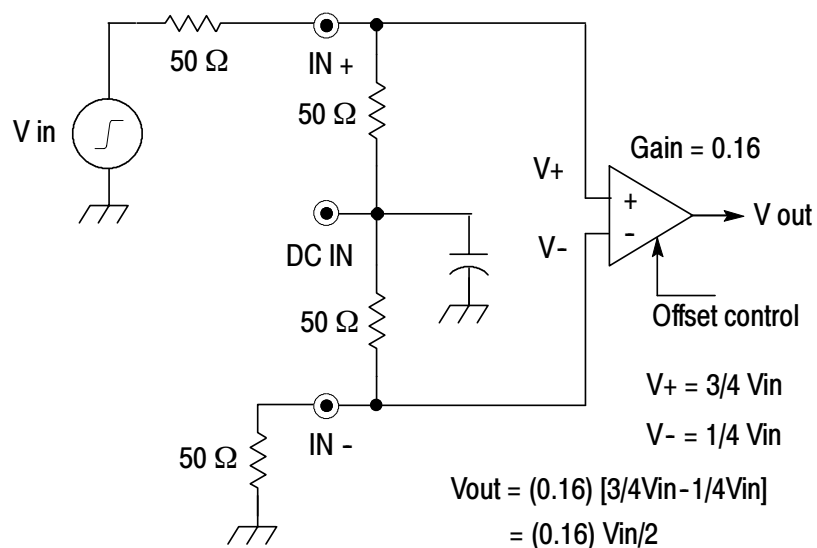

Figure 8: Single-ended drive

If a single-ended measurement is attempted with both the IN-connector and the DC input connector open, an erroneous output signal may result. In the case of a high data rate, single-ended pulse source with a $50\ \Omega$ output impedance, the resulting probe output will appear correctly because the common mode capacitance terminates a high data rate signal.

For lower data rate signals, however, the common mode capacitance has time to charge through the source and termination resistors and produces a waveshape as shown in Figure 9. The data rate determines the actual waveshape. Note that charging of the common mode capacitance results in a differentiated output waveshape. For this reason, the unused SMA input should always be terminated with a matched source termination for single-ended measurements.

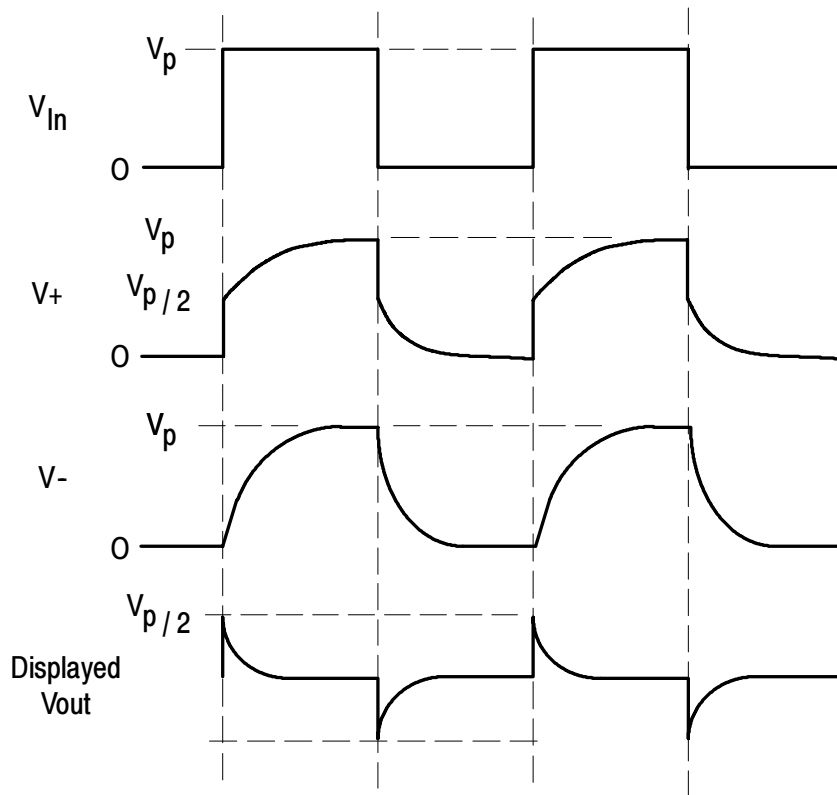

Figure 9: Resultant waveform from an unterminated input

The time constant of the charging waveshape is about 2 μs , which results from the RC time constant of the termination network common mode node capacitance and the source and termination resistance. With both the IN- and DC ports of the probe open, a pulse edge transition at the IN+ connector begins charging the termination network common mode node capacitance through the source and termination resistance. The differentiated output waveshape results from the instantaneous charging current change across the IN+ termination resistor due to a pulse edge transition, followed by the exponential decrease in this charging current as the common mode node capacitance charges.

Matched-Delay Cables

A set of matched-delay cables is included as a standard accessory for the P7350SMA probe. The cable set provides matched signal paths for the signals to be measured, from the circuit SMA connectors to the probe SMA inputs. Accurate measurement of high-speed differential signals can be affected by a variety of different factors, one of which is matched signal paths. Excessive signal delay mismatch between the two signal paths of a high-speed serial data differential signal can result in increasing signal rise time error, until finally, a badly distorted waveform is seen.

The effect of delay mismatch on measured rise time is dependent on both the rise time of the signal source and the specified rise time of the probe used to take the measurement. As can be seen from the rise time data in Table 3 on page 20, for a skew of less than 10 ps, the measured rise time is within a few picoseconds of the minimum rise time for zero skew. Although measurement rise time is not the only signal characteristic affected by signal skew, a skew of less than 10 ps should be acceptable for many serial data compliance tests. The matched-delay cables provided with the probe are specified with a skew of less than 10 ps.

If tighter skew is required for a differential measurement application, manual deskew of the matched cable set is possible with a set of optional phase adjusters. See *Adjusting Cable Skew* on page 33.

Table 3 shows the effect of delay mismatch on the measured rise time of the probe, when driven by a 30 ps rise time TDR pulse source.

Table 3: Effects of delay mismatch on measured rise time

Skew between cables (differential TDR)	Measured rise time (10-90%)
-100 ps	253 ps (distorted)
-75 ps	206 ps (distorted)
-25 ps	106 ps
0 ps	94 ps
10 ps	96 ps
25 ps	104 ps

Figure 10 on page 20 shows the effect on signal pulse edges due to excessive delay mismatches.

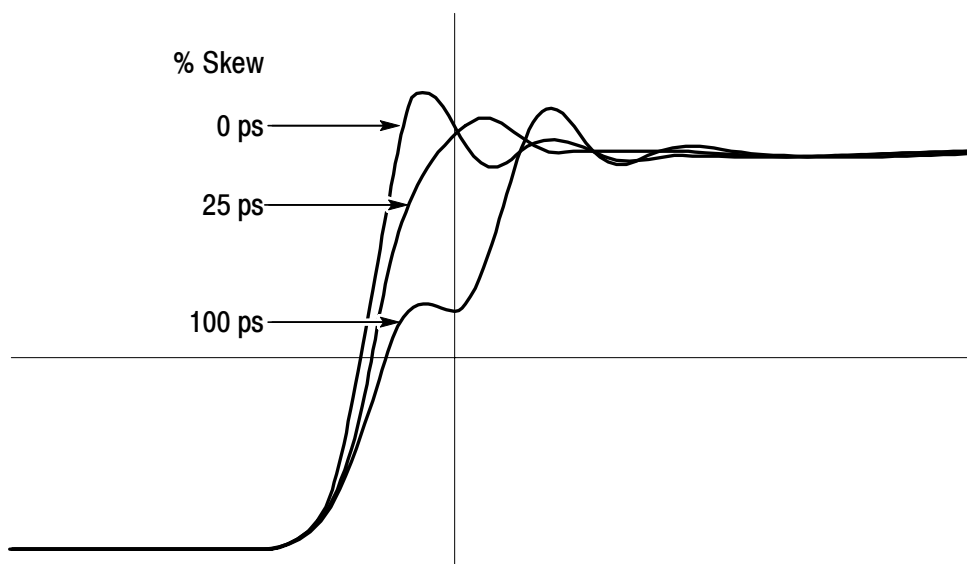

Figure 10: Distorted pulse edge

DC Termination Voltage Input

The P7350SMA probe provides a common mode DC voltage input to the termination network, which includes internal filtering to reduce noise. You can adjust your DC termination voltage within ± 5 volts of either signal input.

The P7350SMA probe has been designed for compliance testing of high-speed, serial data standards such as PCI Express, InfiniBand, SerialATA, XAUI, Gigabit Ethernet, Fibre Channel, and others. All of these high-speed, differential data signals have both common mode and differential mode voltages less than 2 volts. Signal voltages this small will result in termination resistor power dissipation much less than the 0.5 W limit specified for the P7350SMA probe.



CAUTION. *The input termination resistors have a thermal power rating of 0.5 W and are subject to damage if an excessive DC plus AC rms signal is applied. To prevent damaging the probe, see page 22 for instructions on calculating the termination resistor power if you intend to measure signals that exceed the voltage levels of the data standards discussed above.*

The P7350SMA probe can be used to measure differential and single-ended signals with the DC termination voltage input open as long as the SMA inputs are driven or terminated with matched source impedances. Operating the P7350SMA probe with the DC termination voltage input open will, in general, reduce the termination resistor power dissipation.

The DC termination voltage input has been included for flexibility in applications where a common mode pullup or pulldown voltage is required, such as ECL or CML logic signals. The termination resistor power dissipation warning and power dissipation equations are provided for use in exceptional applications where higher voltages are present and may cause damage if misapplied.

If you intend to measure signals that exceed the voltage levels of the data standards discussed above, see *Calculating DC Termination*

Resistor Power and Equations to calculate the power that you will apply to the termination resistors.

NOTE. *For many high-speed serial data applications, the probe can be operated with the V_T terminal open.*

The red (+) and black (-) terminals on the probe head accept standard banana plugs on 0.75-inch centers. It is recommended that all cabling to these banana plugs be made with shielded cables to help prevent noise from affecting your measurement. Dual banana plug-to-BNC adapters and coaxial BNC cables make shielded DC port connections simple. The black terminal is ground and is connected to the outer case of the shielded module that holds the SMA input terminals.

Depending on the measurement application, the DC port can be driven with an externally applied DC voltage, shorted to ground with the banana plug shorting strap that is included with the probe, or left open and unconnected.

If the DC port is not needed to supply a DC termination voltage, it can be used to measure the common mode voltage of an input differential signal with a DMM.

Calculating DC Termination Resistor Power

The maximum power that the termination resistors in the probe can dissipate is 0.5 watt each. To avoid exceeding these limits, before you take measurements, you should consider the power that your system will impose on the termination network. The power that the termination resistors see may be comprised of not only the AC signal, but also any DC component of the waveform.

The power also depends on how you use the DC termination inputs. The DC termination inputs may be left open, shorted together, or an external DC voltage may be applied. If the DC termination input is left open, then there is no DC power dissipated in the termination resistors. When the DC termination input is shorted to ground or driven by an external DC power supply, the DC power dissipation is

often the dominant component to the termination resistor power dissipation.

Use the following examples to help you operate the probe safely.

DC Voltage Applied to SMA Inputs with the DC Termination Voltage Input Grounded

Figure 11 on page 23 illustrates an example of the maximum allowable power being dissipated by the internal termination resistors. This example is simplified by considering the DC component only, and shorting the DC termination input to ground.

The maximum DC voltage that you can safely apply to the SMA inputs is derived from the given parameters—the 50 Ω and 0.5 watt maximum power that each termination resistor is rated for:

$$\begin{aligned}
 V_{in} &= \sqrt{PR} \\
 &= \sqrt{0.5 \text{ W} \times 50 \Omega} \\
 &= 5.0 \text{ V}
 \end{aligned}$$

Note that in this case, a DC current of 100 mA flows through each resistor.

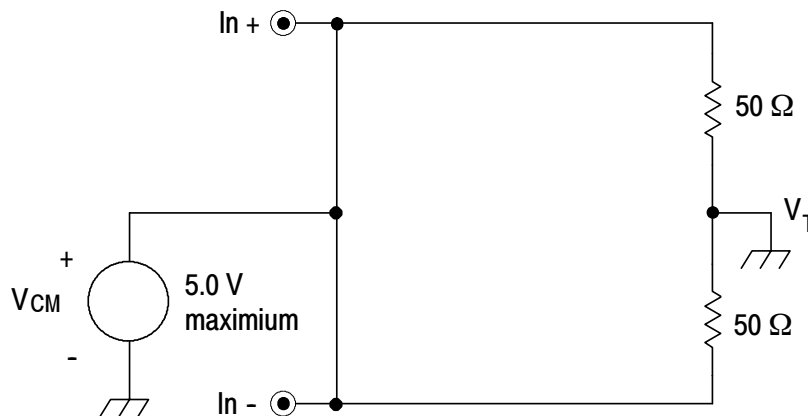

Figure 11: Worst-case power dissipation example

Complementary Input Signal with the DC Termination Voltage Input Open

Consider the single-ended signals shown in Figure 12a on page 24. Each signal is varying by 0.5 volt symmetrically around 0.75 volt. These signals are applied to the probe model as shown in Figure 12b. It should be noted that the input signal model has been simplified by removing any source impedance. A more realistic input signal model would typically include a $50\ \Omega$ source impedance and would require adjustment of the voltage sources to give the equivalent signal at the (In+) and (In-) probe inputs.

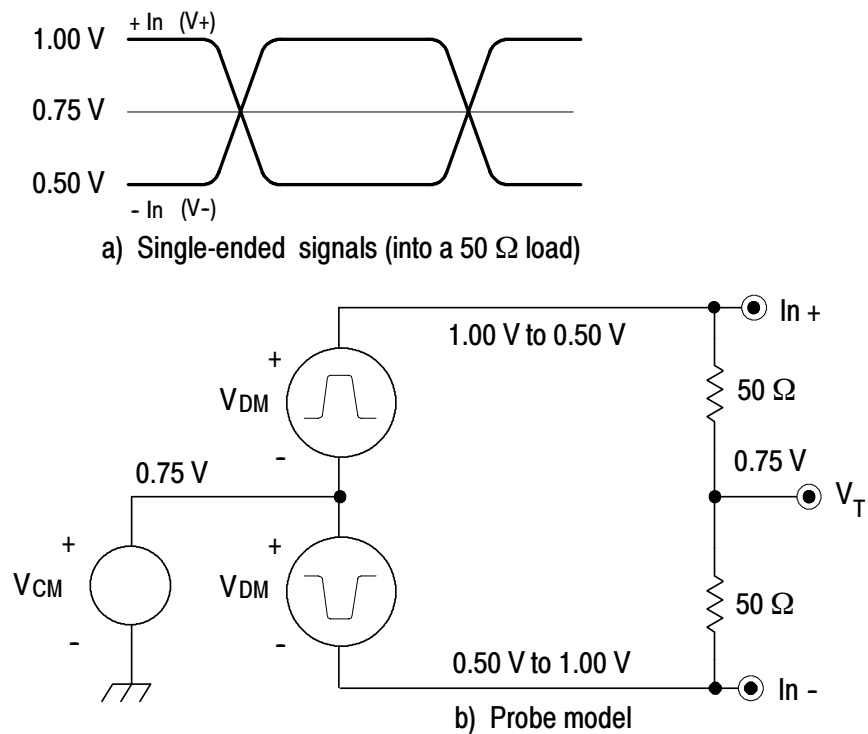

Figure 12: Example of probe with DC input open

The terms used in this discussion are defined as follows:

$$V_{DM} = V_+ - V_- \qquad V_{CM} = \frac{V_+ + V_-}{2}$$

V_T = Termination terminal voltage

Using these terms, the measured peak-to-peak differential voltage, (V_{Diff}), = $2 V_{DM}$, since the differential output voltage swings positive and negative about ground with an amplitude of V_{DM} .

For this example,

$$\begin{aligned} V_{DM} &= 1.00V - 0.50V & V_{CM} &= \frac{1.00V + 0.50V}{2} \\ &= 0.50V & &= 0.75V \end{aligned}$$

$V_T = 0.75V$ (The DC termination terminal is open in this example, so this node is at the common mode voltage.)

The switching signal potential across the two termination resistors (100Ω in series) is the differential mode voltage, 0.5 volt, which equates to 5 mA of current flow. This differential mode current flows alternately one direction and then the other, around the termination network loop as the differential mode voltage switches polarity. Common-mode current only flows initially as the capacitance at the V_T node charges to the common mode voltage.

The total power dissipated is the product of the 5 mA of circuit current and the 0.5 volt drop across both resistors. The result is 2.5 mW of total AC power, or 1.25 mW for each resistor. In this example, with the DC termination terminal open, there is no DC power dissipated by the termination network.

Complementary Input Signal with the DC Termination Voltage Input Shorted (Grounded)

In Figure 13, the same signals as in the previous example are used, but here, the DC termination input is shorted to ground. Each signal is still varying by 0.5 volt symmetrically around 0.75 volt, but now the signals have a path for DC current flow through the two termination resistors to ground.

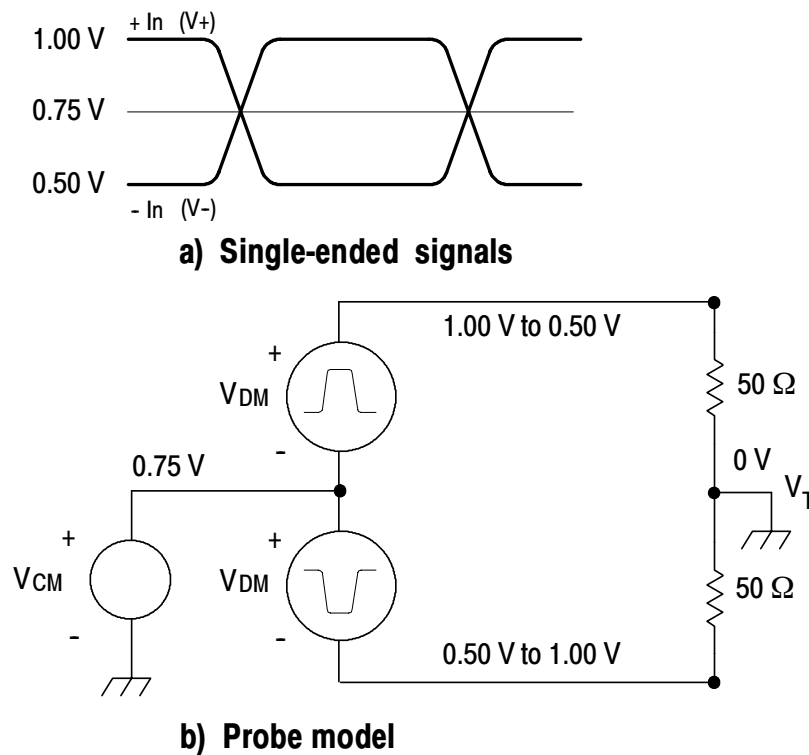

Figure 13: Example of probe with DC input shorted to ground

In this example,

$$V_{DM} = 1.00V - 0.50V = 0.50V$$

$$V_{CM} = \frac{1.00V + 0.50}{2} = 0.75V$$

$$V_T = 0V \text{ (The DC termination terminal is grounded.)}$$

The voltage swing across the 50 Ω termination resistors is still 0.5 volt and 1.0 volt, but now the DC termination terminal is grounded. The resultant current flow of 10 mA and 20 mA, respectively, through the two 50 Ω termination resistors yields a total of 25 mW of power:

$$(10 \text{ mA})^2(50 \Omega) + (20 \text{ mA})^2(50 \Omega) = 25 \text{ mW}$$

Because of the symmetry of the circuit and the input signal, the power dissipation in each termination resistor is 12.5 mW.

The termination resistor power can also be calculated by separately calculating the DC common mode power and the AC power.

The common mode voltage, 0.75 volt, is seen across both 50 Ω termination resistors, so each side of the circuit has 15 mA of current flow. The power is then calculated by multiplying the 15 mA by the 0.75 volt, resulting in 11.25 mW of DC power dissipated by each resistor. The AC power from the 5 mA circulating current calculated in the previous example is 1.25 mW per resistor.

Total power dissipation of each resistor in this example is 12.5 mW, derived from 11.25 mW DC, plus 1.25 mW AC, which is well under the 500 mW maximum.

As can be seen by the two previous examples, grounding the DC termination input increased the DC power dissipation of the termination resistors to nearly ten times that of the AC power, by providing a path to ground for the DC common mode voltage.

Note also that if the DC termination input had been driven with a DC voltage that matched the input V_{CM} value, then there is no DC power dissipated.

Another way to eliminate the DC power dissipation in cases where the signal is DC balanced is by using SMA DC blocks.

Equations and Definitions

The formulas for calculating the power dissipation of the 50 Ω termination resistors with a DC-balanced signal like that modeled in the previous two examples follows:

$$\text{DC power} = \left[\frac{V_{\text{CM}} - V_{\text{T}}}{50} \right] (V_{\text{CM}} - V_{\text{T}}) \text{ per side}$$

$$\text{AC power} = \left[\frac{V_{\text{DM(p-p)}}}{100} \right] \left[\frac{V_{\text{DM(p-p)}}}{2} \right] \text{ per side}$$

The signal source model defined for these equations is as follows:

V_+ and V_- = Single-ended signals into a 50 Ω load

$$V_+ = V_{\text{CM}} + V_{\text{DM}} \quad V_- = V_{\text{CM}} - V_{\text{DM}}$$

This results in the terms to be used in the power equations above:

$$V_{\text{CM}} = \frac{V_+ + V_-}{2} \quad V_{\text{DM}} = \frac{V_+ - V_-}{2}$$

V_{T} = Termination input voltage

Note: With a balanced DC signal, in the equations above, V_{DM} is half of the value of a conventional differential signal.

$$V_{\text{diff}} = V_+ - V_- = 2V_{\text{DM}}$$

Internal Probe Amplifier

The P7350SMA differential probe is designed to measure high frequency, low-voltage circuits. Before connecting the probe to your circuit, take into account the limits for maximum input voltage, the common-mode signal range, and the differential-mode signal range. For specific limits of these parameters, see *Specifications* on page 43.

Maximum Input Voltage

The maximum input voltage is the maximum voltage to ground that the inputs can withstand without damaging the probe input circuitry.



CAUTION. *To avoid damaging the inputs of the P7350SMA differential probe, do not apply more than ± 15 V (DC + peak AC) between each input and ground.*

Note that the 0.5 W power dissipation of the termination resistor must also be considered when the DC termination input is driven and may further limit the maximum allowable signal input voltage.

Common-Mode Signal Range

The common-mode signal range is the maximum voltage that you can apply to each input, with respect to earth ground, without saturating the input circuitry of the probe. A common-mode voltage that exceeds the common-mode signal range may produce an erroneous output waveform even when the differential-mode specification is met.

Differential-Mode Signal Range

The differential-mode signal range is the maximum voltage difference between the plus and minus inputs that the probe can accept without distorting the signal. The distortion from a voltage that is too large can result in a clipped or otherwise distorted and inaccurate measurement.

Differential Offset Range

The differential offset is used primarily in single-ended measurements made with the probe. A single-ended measurement is made with a differential probe by grounding the probe (-) input pin. If a single-ended DC common mode voltage is present at the probe (+) input pin, it is effectively converted to a DC differential mode voltage. This DC differential mode voltage can be nulled out using the differential offset control, if it is within the 1.25 V differential offset range. By nulling out this DC differential mode voltage, the dynamic range window of the probe is effectively expanded, although the 2.5 V differential signal range limit still applies within the expanded dynamic range window.

As shown in the simplified block diagram in Figure 14, the DC offset signal from the oscilloscope is buffered by a single-ended amplifier in the compensation box of the probe and passed to the offset input of the probe head amplifier. The probe head amplifier then converts the single-ended offset signal to a complementary differential offset signal that drives the ends of the input attenuator. The differential offset signal effectively cancels out differential DC voltages applied to the P7350SMA input pins.

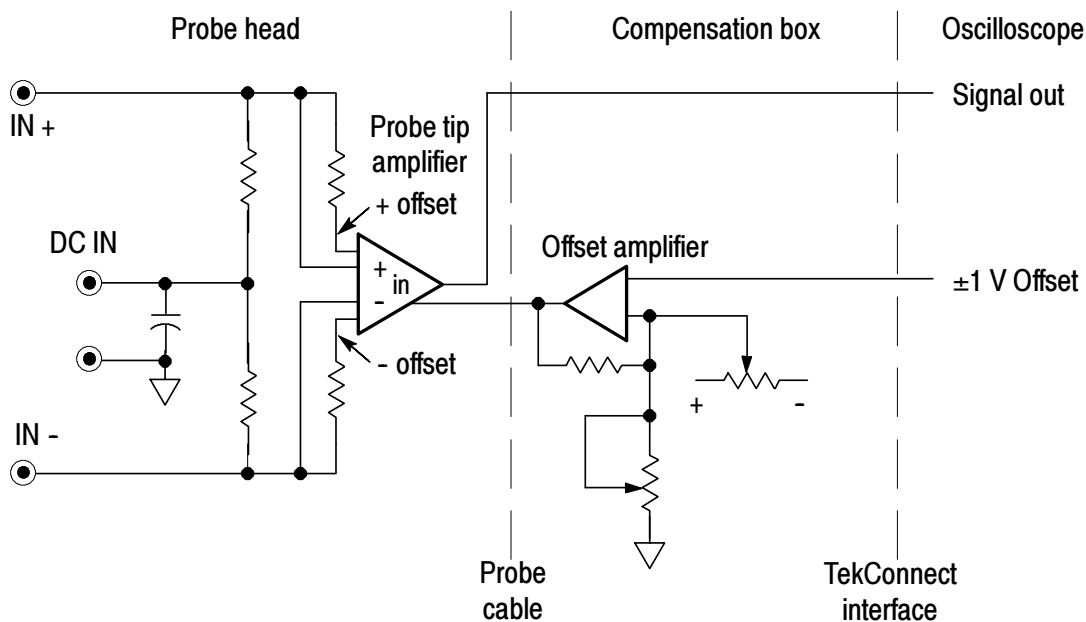

Figure 14: Probe amplifier and offset circuit

Common-Mode Rejection

The common-mode rejection ratio (CMRR) is the ability of a probe to reject signals that are common to both inputs. More precisely, CMRR is the ratio of the differential gain to the common-mode gain. The higher the ratio, the greater the ability to reject common-mode signals. For additional information about CMRR, see page 40.

Input Impedance and Probe Loading

Each input of the P7350SMA differential probe has an input impedance of $50\ \Omega$. See Figure 15.

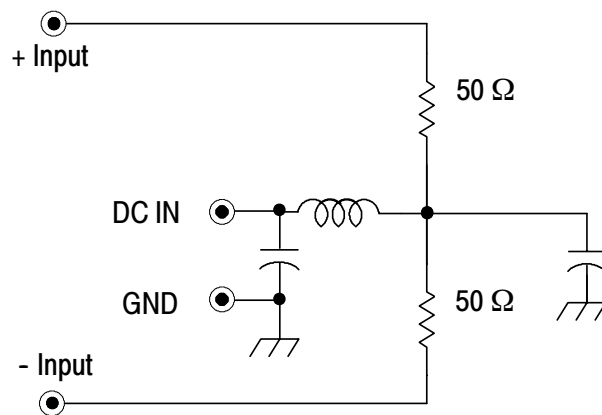

Figure 15: Typical probe input model

The lower the impedance of the probe relative to that of the source, the more the probe loads the circuit under test and reduces the signal amplitude. With an input impedance of $50\ \Omega$, the P7350SMA probe is designed for use with $50\ \Omega$ systems. The broadband quality of the P7350SMA probe $50\ \Omega$ inputs is specified with the differential input return loss specification. For specific limits of these parameters, see *Specifications* on page 43.

Checking the Skew Between Inputs

The time-delay difference (skew) between the two SMA input terminals of the probe is typically less than 1 ps. If you use the matched-delay SMA cable pair supplied with the probe, the guaranteed skew between the cable pair is 10 ps or less. You can bring the skew to within 1 ps with the cables by using a pair of phase adjusters (see *Optional Accessories* on page 5).

The skew specification of the probe is guaranteed by design and somewhat difficult to measure. The skew of the matched-delay cable pair is guaranteed to be 10 ps or less, but may be much better than the guaranteed limit.

You can measure the skew of the cable pair by connecting the cables to a Tektronix 80E04 Sampling Head, configured for a TDR output. Figure 16 on page 33 shows a setup for checking the skew.

1. Turn on the equipment and let it warm up for 20 minutes. Do not connect the cables to the sampling head yet.
2. Do a system compensation for the TDR module, and then verify the skew of the two outputs with the TDR outputs open, using a common-mode TDR drive.

Skew between the two outputs can be compensated with the TDR module deskew control. Refer to your sampling head or oscilloscope manual for instructions.

3. Connect the matched cable pair to the TDR outputs, as shown in Figure 16 on page 33.

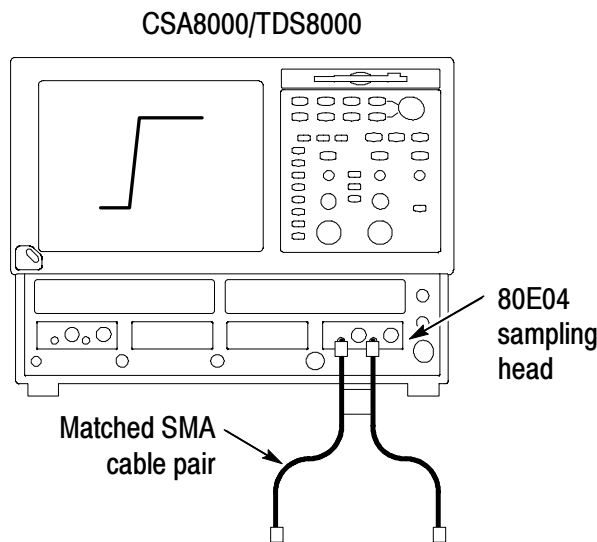

Figure 16: Checking skew between inputs

4. The measured skew should be less than 10 ps. Adjust the horizontal scale to locate the pulse (to account for the 1.45 ns of cable delay). If you use the system cursors, be aware that the displayed time is the round trip time (step and reflection). You need to divide the displayed time difference by 2 to derive the actual skew.

If you need the skew to be less than 10 ps, see *Adjusting Cable Skew*.

Adjusting Cable Skew

If you want to minimize the skew introduced by the cables, you can use a pair of phase adjusters (see *Optional Accessories* on page 5) to bring the skew to within 1 ps. The phase adjusters have male and female SMA connectors to simplify connections to your measurement system.

You must add a phase adjuster on each cable to balance the delay and insertion loss introduced by the phase adjuster. You only adjust (add delay to) the phase adjuster on the cable with the shorter delay.

The following instructions assume that you have performed *Checking the Skew Between Inputs*. (The cables may already have only a few picoseconds of skew, making adjustments unnecessary.) If you have determined that you need to adjust the skew from <10 ps to <1 ps, do the remaining steps:

5. Connect the phase adjusters to the cables.
6. On the cable with the longer delay, loosen the phase adjuster locking nuts, set the phase adjuster to minimum delay (shortest length), and secure the locking nuts. See Figure 17 on page 34.

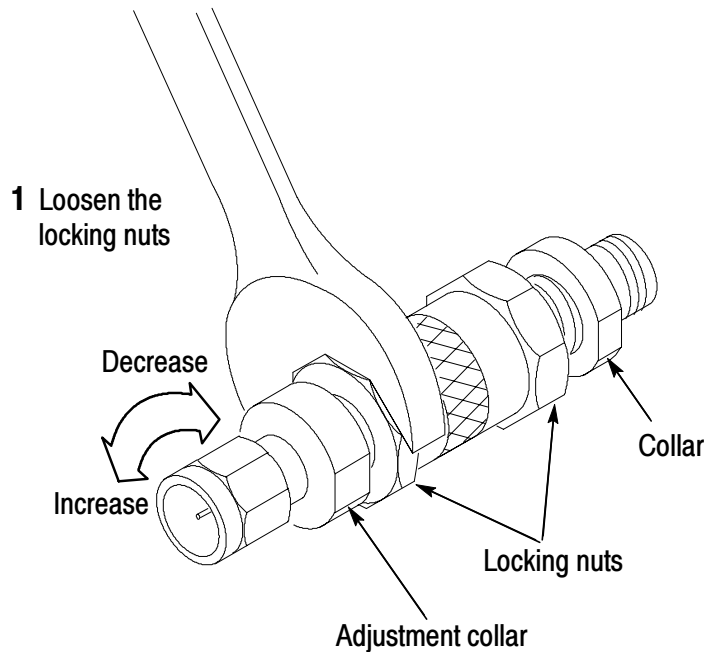

- 2 Turn adjustment collar while observing oscilloscope display

Figure 17: Using the phase adjuster

7. Loosen the locking nuts on the adjuster connected to the other cable (with the shorter delay).
8. While observing the oscilloscope display, turn the collar on the phase adjuster counterclockwise to increase the delay.
9. When the displayed skew on screen is less than 1 ps, tighten the locking nuts.
10. Confirm that the skew is acceptable after you tighten the locking nuts, as the adjustment may change slightly during tightening.
11. Disconnect the cables from the sampling head, and connect them to the P7350SMA probe head.

Deskewing Probes

You can measure the skew between two P7350SMA probes by using a Tektronix 80E04 Sampling Head configured for a TDR output. Because the skew of the P7350SMA probe inputs is less than 1 ps, two P7350SMA probes can be deskewed using single-ended drive signals from a dual-channel TDR source. The TDR output provides a pair of time-aligned pulses that you can use to compare probe response times, and if necessary, adjust them to match (deskew).

Figure 18 on page 36 shows a setup for checking and deskewing two probes. Deskewing aligns the time delay of the signal path through the oscilloscope channel and probe connected to that channel, to the time delay of other channel/probe pairs of the oscilloscope.

If you need to deskew more than two probes, keep one deskewed probe connected to the sampling head as a reference (after deskewing two probes), and deskew additional probes to that probe. In this procedure, Channel 1 is used as the reference channel.

1. Set up the equipment as shown in Figure 18 and let it warm up for 20 minutes, but don't make any connections to the TDR outputs yet.
2. Do a system compensation for the TDR module, and then verify the skew of the two outputs with the TDR outputs open, using a common-mode TDR drive.

Skew between the two outputs can be compensated with the deskew control. Refer to your sampling head or oscilloscope manual for instructions.

3. Attach the probes to the TDR outputs as shown in Figure 18.

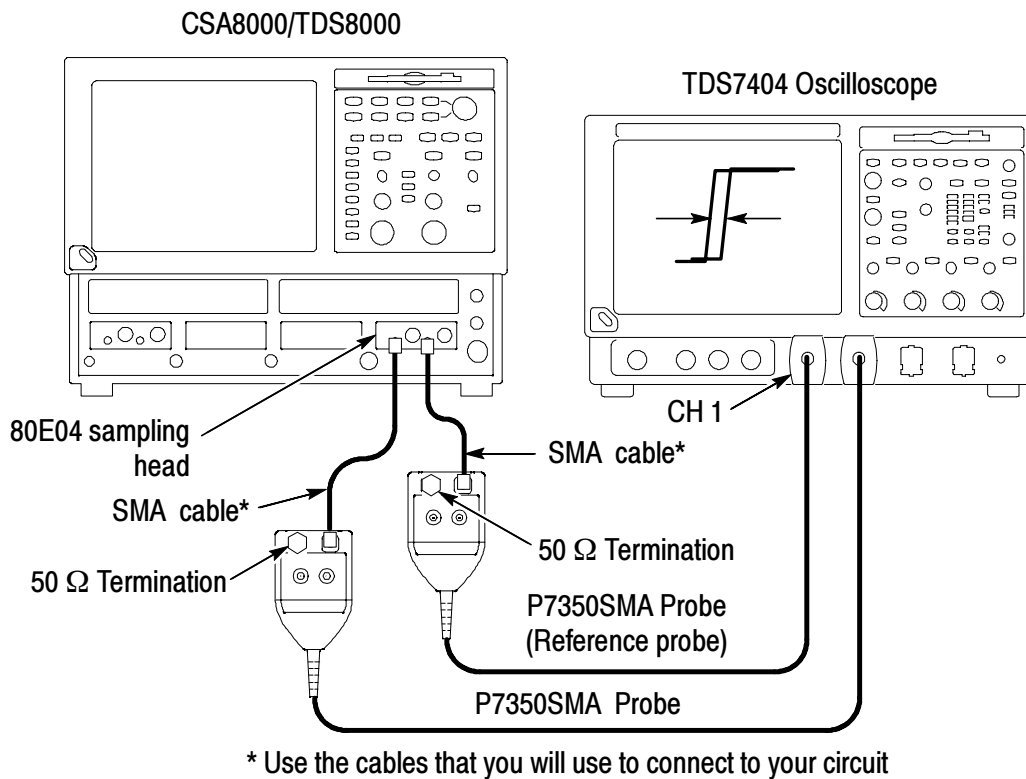

Figure 18: Deskewing two P7350SMA probes

4. Display the channel(s) that you want to deskew.
5. Push the **AUTOSET** button on the instrument front panel.
6. Turn averaging on to stabilize the display.
7. Adjust vertical **SCALE**, and **POSITION** (with active probes, adjusting **offset** may be required) for each channel so that the signals overlap and are centered on-screen.
8. Adjust horizontal **POSITION** so that a triggered rising edge is at center screen.
9. Adjust horizontal **SCALE** so that the differences in the channel delays are clearly visible.
10. Adjust horizontal **POSITION** again so that the rising edge of the Channel 1 signal is exactly at center screen. Now, if you want,

you can use the measurement cursors to display the channel-channel skew, and input this value in step 14.

- 11.** Touch the **VERT** button or use the **Vertical** menu to display the vertical control window.
- 12.** Touch the Probe **Deskew** button to display the channel-deskew control window.
- 13.** In the **Channel** box, select the channel that you want to deskew to Channel 1.

NOTE. If possible, do the next step at a signal amplitude within the same attenuator range (vertical scale) as your planned signal measurements. Any change to the vertical scale after deskew is complete may introduce a new attenuation level (you can generally hear attenuator settings change) and, therefore, a slightly different signal path. This different path may cause up to a 200 ps variation in timing accuracy between channels.

- 14.** Adjust the deskew time for that channel so that the signal aligns with that of Channel 1. You can do this several ways: Click on the **Deskew** field and input the time value you measured with the cursors in step 10, or you can use the front-panel or on-screen controls to position the signal.
- 15.** Repeat steps 3 through 14 for each additional channel that you want to deskew.

Reference

This section contains important reference information about differential measurements and how to increase the accuracy of your measurements.

Differential Measurements

Devices designed to make differential measurements avoid the problems posed by single-ended systems. These devices include a variety of differential probes, differential amplifiers, and isolators.

The differential amplifier (see Figure 19) is at the heart of any device or system designed to make differential measurements. Ideally, the differential amplifier rejects any voltage that is common to the inputs and amplifies any difference between the inputs. Voltage that is common to both inputs is often referred to as the Common-Mode Voltage (V_{CM}) and voltage that is different as the Differential-Mode Voltage (V_{DM}).

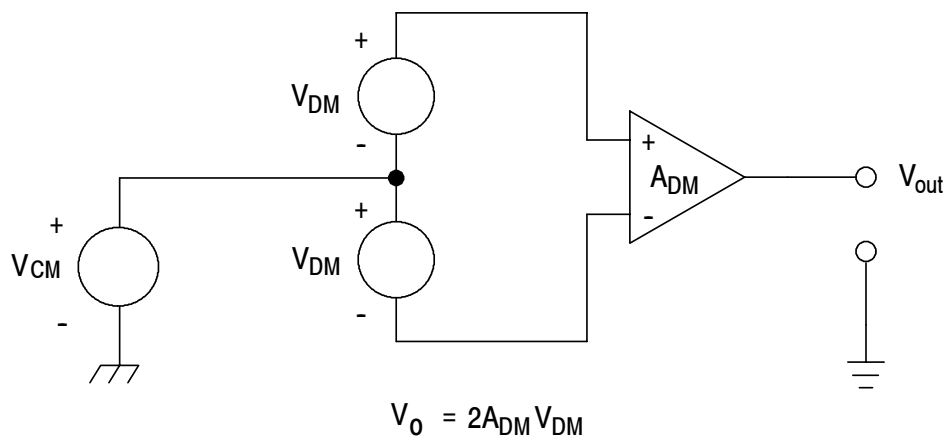

Figure 19: Simplified model of a differential amplifier

Common-Mode Rejection Ratio

In reality, differential amplifiers cannot reject all of the common-mode signal. The ability of a differential amplifier to reject the common-mode signal is expressed as the Common-Mode Rejection Ratio (CMRR). The CMRR is the differential-mode gain (A_{DM}) divided by the common-mode gain (A_{CM}). It is expressed either as a ratio or in dB.

$$CMRR = \frac{A_{DM}}{A_{CM}} \quad dB = 20 \log \frac{A_{DM}}{A_{CM}}$$

CMRR generally is highest (best) at DC and degrades with increasing frequency.

Figure 21 on page 46 shows the CMRR of the P7350SMA differential probe. This derating chart assumes a common-mode signal that is sinusoidal. The lower the input impedance of the probe relative to the source impedance, the lower the CMRR. Significant differences in the source impedance driving the two inputs will also lower the CMRR.

Extending the Input Connections

At times it may be necessary to extend the probe inputs with cables that are longer than the standard 12 inch cables. The 12 inch cables are precision-matched to minimize time-delay differences (skew). If you substitute cables, you should use low-loss, flexible cables and keep the lengths matched and as short as possible to minimize skew and optimize common-mode rejection. Check the skew between the cables, and if necessary, use the optional phase adjusters to minimize the skew.

Extending the input leads will also increase the skin loss and dielectric loss, which may result in distorted high-frequency pulse edges. You should take into account any effects caused by the extended leads when you take a measurement.

InfiniBand

A number of high-speed serial data communication standards have been introduced to address the need for next generation I/O connectivity. One of these interface standards, Infiniband, is briefly discussed here.

An Infiniband communication lane includes two independent differential signaling paths, one for transmit and one for receive, both operating at a 2.5 Gb/s rate. As shown in the Figure 20 example, the differential output parameter is specified as a peak-to-peak voltage difference, and thus the signal swing on each pin of the driver is half that value.

The V_{diff} signal shown in Figure 20b is measured with a differential probe connected between the two signals in Figure 20a. The V_{diff} signal represents the result of the receiver processing the two complementary input signals from the driver shown in Figure 20a, and cannot be measured directly as a single-ended signal.

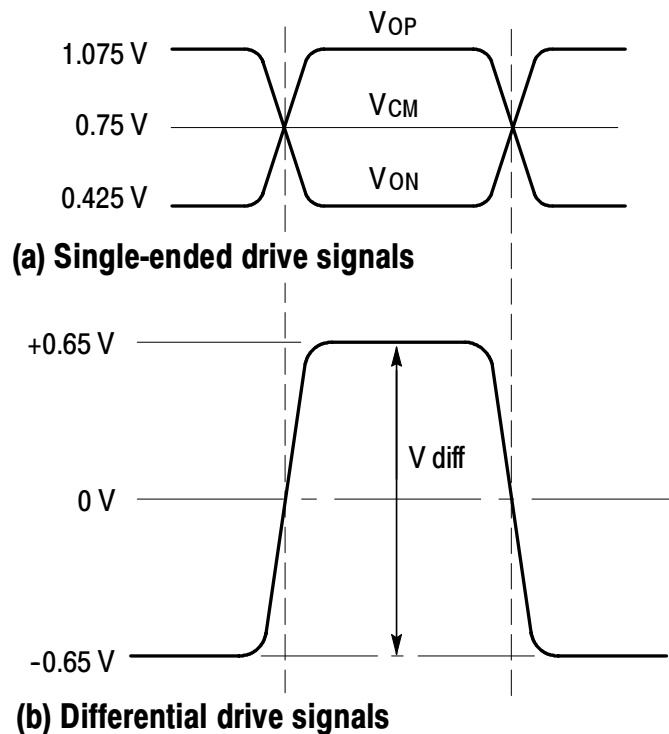

Figure 20: InfiniBand signals

Appendix A: Specifications

The specifications in Tables 4 through 6 apply to a P7350SMA probe installed on a TDS6604 oscilloscope. The probe must have a warm-up period of at least 20 minutes and be in an environment that does not exceed the limits described in Table 4. Specifications for the P7350SMA differential probe fall into three categories: warranted, typical, and nominal characteristics.

Warranted Characteristics

Warranted characteristics (Table 4) describe guaranteed performance within tolerance limits or certain type-tested requirements.

Warranted characteristics that have checks in the *Performance Verification* section are marked with the ✓ symbol.

Table 4: Warranted electrical characteristics

Characteristic	Description
✓ Differential rise time, 10-90% (probe only)	≤100 ps, +20 °C to +30 °C (+68 °F to +86 °F), 500 mV differential step
✓ DC gain	0.16 ±2% (corresponds to 6.25 X attenuation)
✓ Output offset voltage	±10 mV +20 °C to +30 °C (+68 °F to +86 °F)
✓ Differential-mode input resistance	100 Ω ±2% (internally per side; add 0.15 Ω if measuring at SMA probe tips)
Maximum nondestructive common-mode input voltage	±15 V (DC + peak AC) on either SMA input or on the termination voltage banana plug input
Maximum termination resistor power rating	<500 mW per side (see page 22 for instructions on calculating)
Temperature ¹	Operating: 0 to +40 °C (+32 to +104 °F) Nonoperating: -55 to +75 °C (-131 to +167 °F)

Table 4: Warranted electrical characteristics (Cont.)

Characteristic	Description
Humidity	Operating: 0-90% RH, tested at +30 to + 40 °C (+68 to +104 °F) Nonoperating: 0-90% RH, tested at +30 to + 60 °C (+68 to +140 °F)

¹ **WARNING. To avoid a burn hazard at high temperatures, do not touch the probe with bare hands at non-operating temperatures above +70 °C.**

Typical Characteristics

Typical characteristics (Tables 5 and 7) describe typical but not guaranteed performance.

Table 5: Typical electrical characteristics

Characteristic	Description
Bandwidth (probe only)	DC to ≥ 5 GHz (-3dB)
Differential rise time (probe only), 20-80%	65 ps, +20 °C to +30 °C (+68 °F to +86 °F), 500 mV differential step
Single-ended rise time (probe only), 20-80%	105 ps, +20 °C to +30 °C (+68 °F to +86 °F), 250 mV step
Differential signal range	± 2.5 V
Differential signal input skew	<1 ps
Differential offset range	± 1.25 V
Differential input return loss	>20 dB @625 MHz (fundamental for 1.25 Gb/s) >16 dB @1.25 GHz (fundamental for 2.5 Gb/s) >14 dB @1.56 GHz (fundamental for 3.125 Gb/s) >12 dB @2.50 GHz >10 dB @3.125 GHz

Table 5: Typical electrical characteristics (Cont.)

Characteristic	Description
Common-mode signal range	+6.25 V to -5.0 V
Common-mode input return loss	>7.5 dB to 5 GHz
Common-mode rejection ratio	≥60 dB at DC ≥55 dB at 1 MHz ≥50 dB at 30 MHz ≥30 dB at 1 GHz
Linearity	±1% or less of dynamic range
Delay time	5.66 ns
Probe-to-probe delay time variation	600 ps difference between any two probes
Common-mode input resistance	50 Ω ±1% (internally per side; add 0.7 Ω if measurement is made from external terminals)
Noise, referred to input	46 nV/√Hz @100 MHz
DC Offset Scale Accuracy (gain of offset signal path)	±2.0% (of 6.25X actual probe gain)
DC Offset Drift	150 μV/°C or less at output of probe 0.94 mV/°C or less displayed on screen with TekConnect interface
DC Voltage Measurement Accuracy (referred to input)	±[(2% of input relative to offset) + (2% of offset) + 62.5 mV + 50.0 mV] gain error = ±2% of input voltage relative to offset offset gain error = ±2% of effective offset at probe tip output zero = ±62.5 mV effective at probe tip linearity error = ±1.0% of 5.0 V dynamic range (50.0 mV)

Figure 21 shows the typical common-mode and differential gain of the probe. The CMRR can be found by subtracting the common-mode gain from the differential gain. For example, -80 dB CM gain equals approximately +67 dB CMRR.

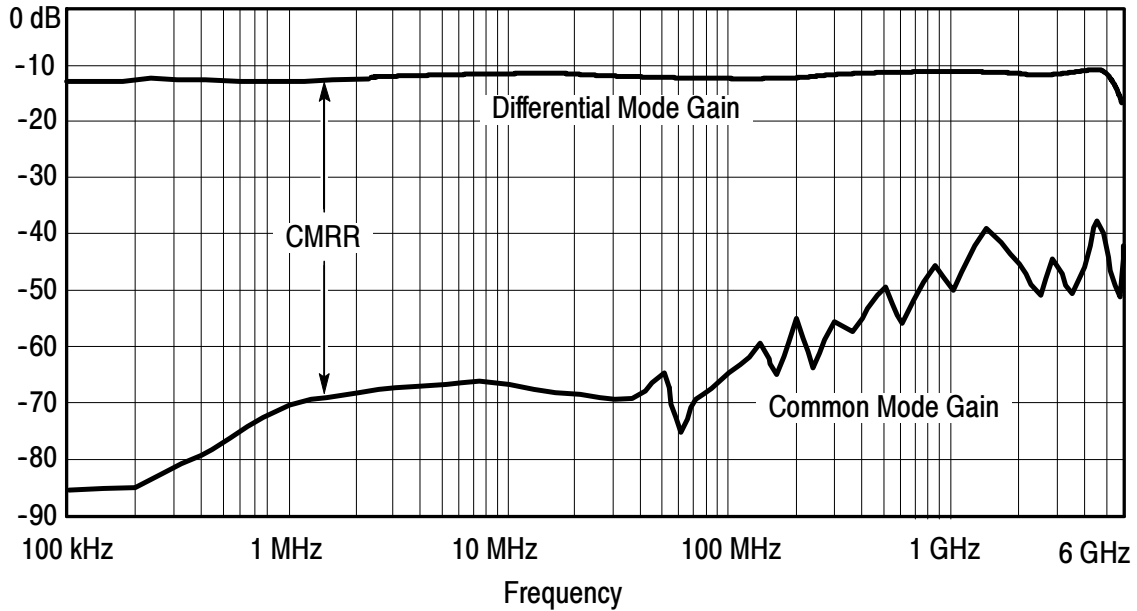

Figure 21: Typical common- and differential-mode gain plots

Figures 22 and 23 show typical differential input return loss and differential-mode bandwidth plots for the probe.

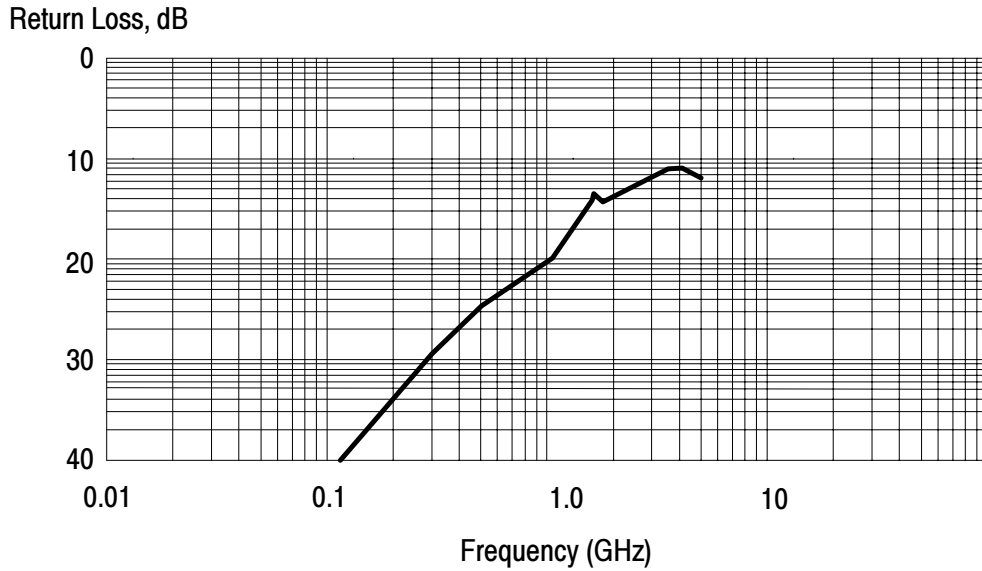

Figure 22: Typical differential input return loss

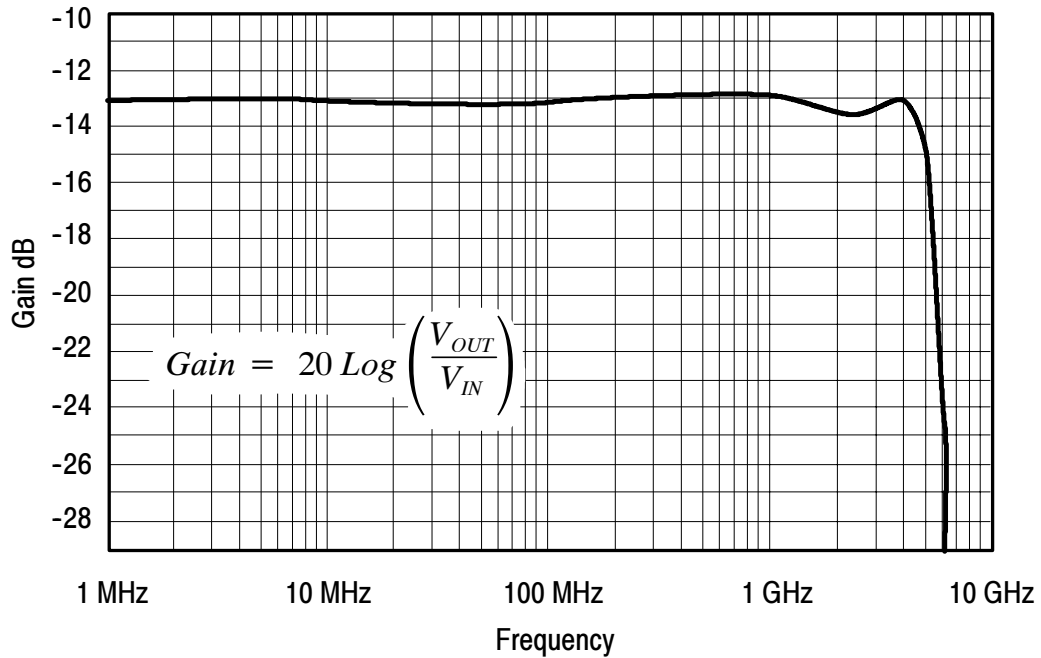

Figure 23: Typical differential-mode bandwidth

Nominal Characteristics

Nominal characteristics (Table 6) describe guaranteed traits, but the traits do not have tolerance limits.

Table 6: Nominal electrical characteristics

Signal input configuration	Differential (two SMA inputs, + and -)
Termination voltage input configuration	DC (two banana jack inputs, + and -)
Attenuation	6.25 X ²
Input coupling	DC
Output coupling and termination	DC, terminate output into 50 Ω
Common-mode termination capacitance	0.022 μF ±10%

² **All TekConnect host instruments recognize this gain setting and adjust the Volts/Div setting to correspond to a normal 1-2-5 sequence of gains.**

Mechanical Characteristics

The mechanical characteristics of the probe are listed in Table 7, and the dimensions are shown in Figure 24 on page 49.

Table 7: Typical mechanical characteristics

Dimensions, control box	43.8 mm × 31.8 mm × 91.5 mm (1.72 in × 1.25 in × 3.60 in)
Dimensions, probe head	35.6 mm × 55.9 mm × 48.3 mm (1.40 in × 2.20 in × 3.40 in)
Dimensions, output cable	1.2 m (47 in)
Unit weight (probe head only)	150 g (5.3 oz)
(probe and comp box)	290 g (10.2 oz)
Shipping weight (includes shipping materials)	1.38 kg (3.1 lb)

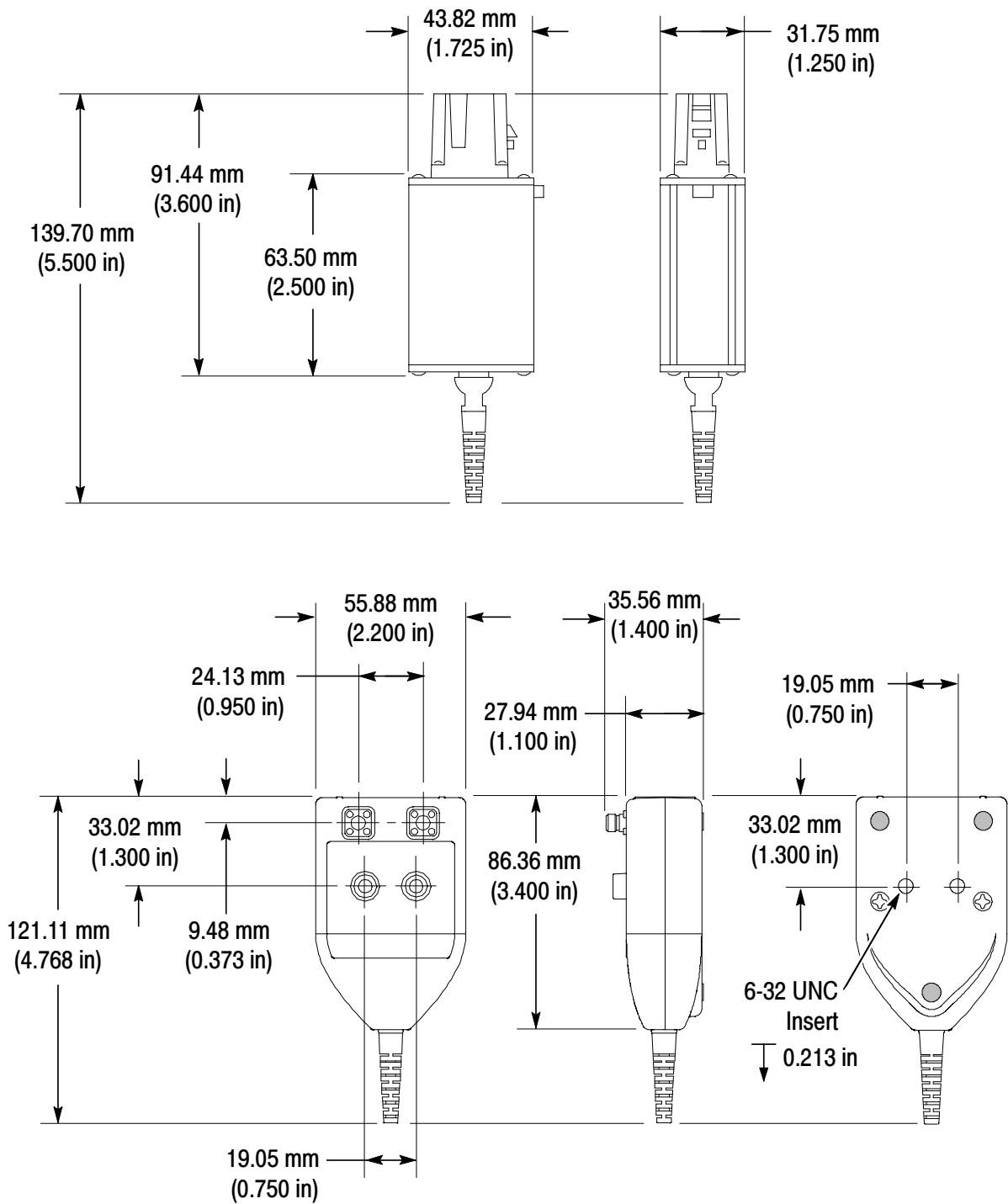

Figure 24: Probe head and compensation box dimensions

Appendix B: Performance Verification

Use the following procedures to verify specifications of the probe. Before beginning these procedures, refer to page 65 and photocopy the test record, and use it to record the performance test results. The recommended calibration interval is one year.

These procedures test the following specifications:

- Differential mode input resistance
- Output offset zero
- DC gain accuracy
- Rise time-differential mode

Equipment Required

Refer to Table 8 for a list of the equipment required to verify the performance of your probe.

Table 8: Equipment required for performance verification

Item description	Performance requirement	Recommended example ¹
Oscilloscope	TekConnect interface	Tektronix TDS7404
Sampling Oscilloscope		Tektronix TDS8000
Sampling Module	20 GHz bandwidth	Tektronix 80E04
Sampling Module	12 GHz bandwidth	Tektronix 80E02
DMM (2), with leads	0.1 mV and 0.01 Ω resolution	Fluke 187 or equivalent
Dual Power Supply	5.0 VDC at 1 mA	Tektronix PS280
TekConnect Interface Calibration Adapter	See page 54	067-0422-00
Feedthrough Termination	BNC, 50 $\Omega \pm 0.05 \Omega$	011-0129-00

Table 8: Equipment required for performance verification (Cont.)

Item description	Performance requirement	Recommended example¹
Coaxial cable	Male-to-Male SMA	012-0649-00
Coaxial cable	Dual, matched-delay Male-to-Male SMA	174-4866-00 ²
Coaxial cables (3)	Male-to-Male BNC, 50 Ω	012-0057-01
Test leads (2)	Banana plug ends, red	012-0031-00
Test leads (2)	Banana plug ends, black	012-0039-00
Shorting strap	Banana plug ends	012-1667-xx ²
Adapter	TekConnect-to-SMA	TCA-SMA
Adapters (3)	SMA Male-to-BNC Female	015-1018-00
Adapter	BNC Male-to-SMA Female	015-0572-00 ²
Adapters (3)	BNC Female-to-Dual Banana	103-0090-00
SMA torque wrench	5/16-in, 7 in-lb.	

¹ **Nine-digit part numbers (XXX-XXXX-XX) are Tektronix part numbers.**

² **Standard accessory included with probe**

Special Adapters Required

Some of the adapters listed in Table 8 are available only from Tektronix. These adapters are described on the following pages.

TekConnect-to-SMA Adapter

The TekConnect-to-SMA Adapter, Tektronix part number TCA-SMA, allows signals from an SMA cable or probe to be connected to a TekConnect input. See Figure 25. Connect and disconnect the adapter the same way as you do the probe.

This adapter is an oscilloscope accessory that may be used for measurement applications, as well as these performance verification procedures.

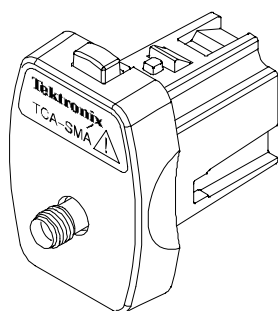

Figure 25: TekConnect-to-SMA Adapter

TekConnect Interface Calibration Adapter

The TekConnect Interface Calibration Adapter, Tektronix part number 067-0422-00, is shown in Figure 26 on page 54. The adapter connects between the host instrument and the probe under test and provides connectors for internal probe measurements. This adapter is an optional accessory that is only used for probe calibration procedures.

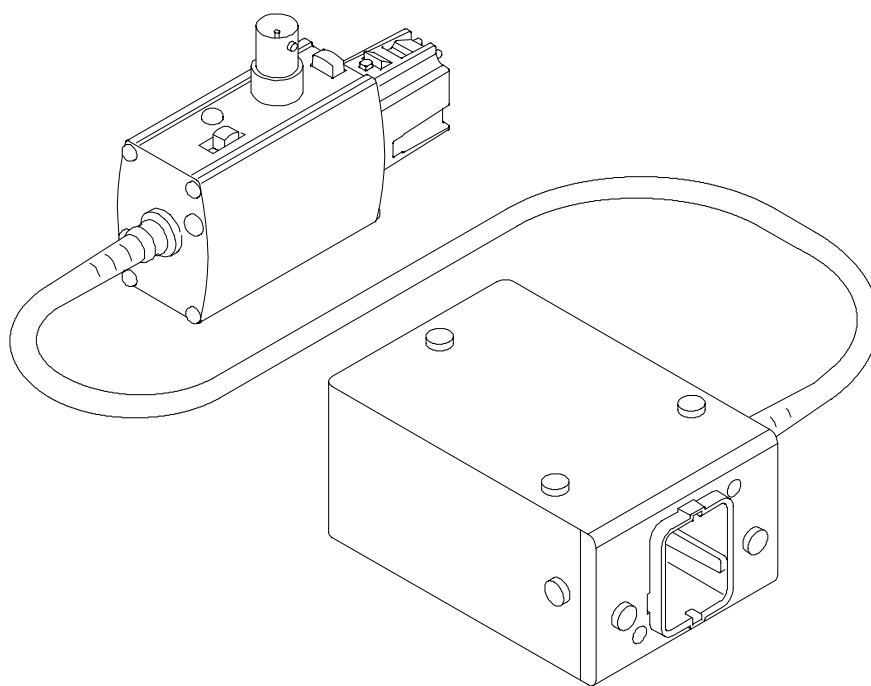
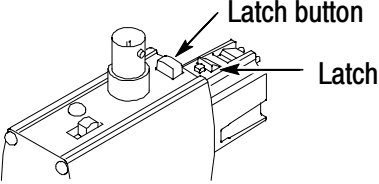
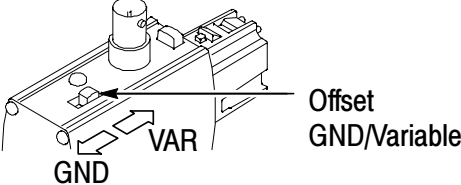
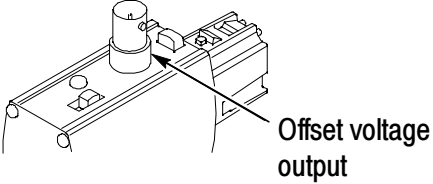
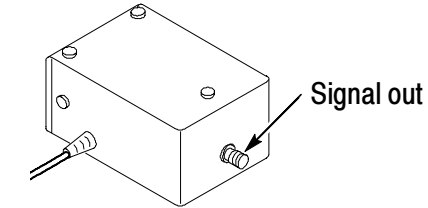

Figure 26: TekConnect Interface Calibration Adapter

When the adapter is connected to the oscilloscope, the adapter is identified as a valid calibration device. However, additional power supplies necessary to power the probe are not enabled until a TekConnect probe is connected to the adapter and identified by the oscilloscope. When a probe is detected through the adapter, the Volts/div readout on the oscilloscope displays ##.

Refer to Table 9 on page 55 for detailed features of the calibration adapter.

Table 9: TekConnect Interface Calibration Adapter features

Feature	Description
 <p>Latch button Latch</p>	<p>Latch button. The spring-loaded latch mechanically retains the adapter to the oscilloscope. To release the adapter, grasp the adapter housing, depress the latch button, and pull the adapter straight out of the oscilloscope.</p>
 <p>Offset GND/Variable GND VAR</p>	<p>Offset output select switch. The offset output switch selects between ground and the offset voltage level from the oscilloscope.</p> <p>Leave the switch in the ground position for the performance verification procedures. The variable position is only used in the adjustment procedures.</p>
 <p>Offset voltage output</p>	<p>Offset voltage. The offset voltage of the probe is accessed through the BNC connector.</p> <p>Measure the offset voltage using a DVM, BNC coaxial cable and BNC-to-dual-banana jack.</p>
 <p>Signal out</p>	<p>Signal out. The SMA connector on the rear of the box allows for direct monitoring of the probe signal.</p>

Equipment Setup

Use this procedure to set up the equipment to test the probe. Wear the antistatic wriststrap when performing these procedures.

1. Connect the probe calibration adapter to the oscilloscope.
2. Connect the probe to the probe calibration adapter.
3. Turn on the oscilloscope and enable the channel.
4. Allow 30 minutes for the equipment to warm up.

Input Resistance

This test checks the differential mode input resistance—the resistance between each SMA input. The test is performed with the probe disconnected from the calibration adapter. After you complete this test, reconnect the probe to the calibration adapter to keep the probe at operating temperature.

1. Zero the DMM on the lowest scale that can measure 100 Ω .
2. Probe the center contacts of the SMA input connectors as shown in Figure 27.
3. Measure the resistance and write down the value.
4. Reverse the DMM connections and repeat the measurement. Write down the value.
5. Add the two measurements from steps 3 and 4, and divide the total by two. Subtract 0.15 Ω from the result to account for the internal path resistance, and record the result in the test record.
6. Connect the probe to the calibration adapter so that the probe warms up to operating temperature for the remaining tests.

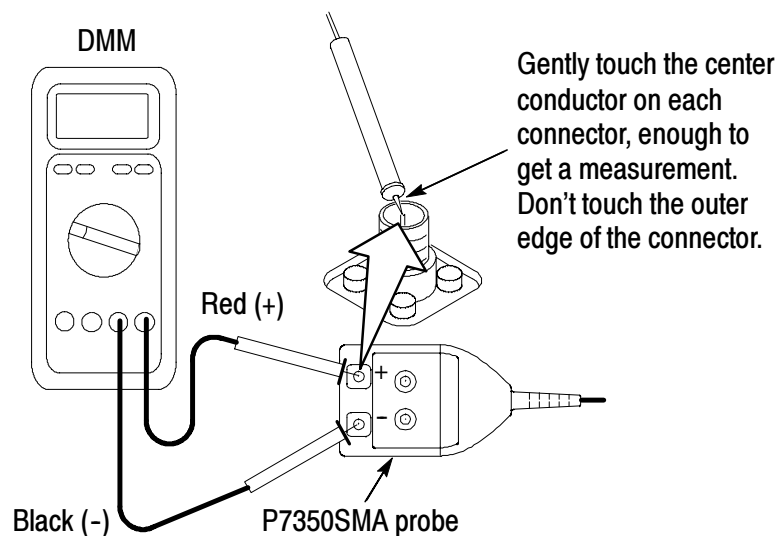

Figure 27: Checking differential mode input resistance

Output Offset Zero

1. Connect the equipment as shown in Figure 28.
2. Connect the shorting strap to the banana jacks on the probe.
3. Connect an SMA cable between the two SMA inputs on the probe.

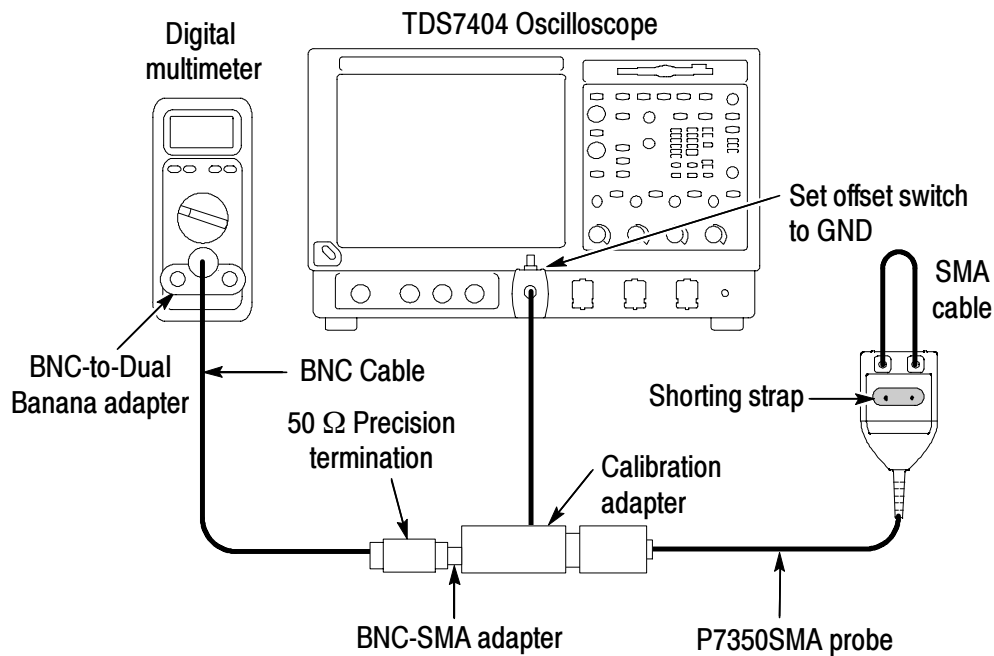

Figure 28: Setup for the output offset zero test

4. Set the offset switch on the calibration adapter to **GND**.

NOTE. Leave the offset switch in the ground position for all of the performance verification checks.

5. Set the multimeter to read DC volts.
6. Verify that the output voltage is 0 V, ± 10 mV.
7. Record the results on the test record.

DC Gain Accuracy

1. Connect the probe to the power supplies as shown in Figure 29. Make sure the ground tabs on the BNC-to-dual banana plug adapters are connected to the ground connections on the power supplies. Monitor the source voltage with one of the DMMs.
2. Set the voltage on each power supply to approximately +0.25 V (+0.5 V total). Record this source voltage as V_{in1} .

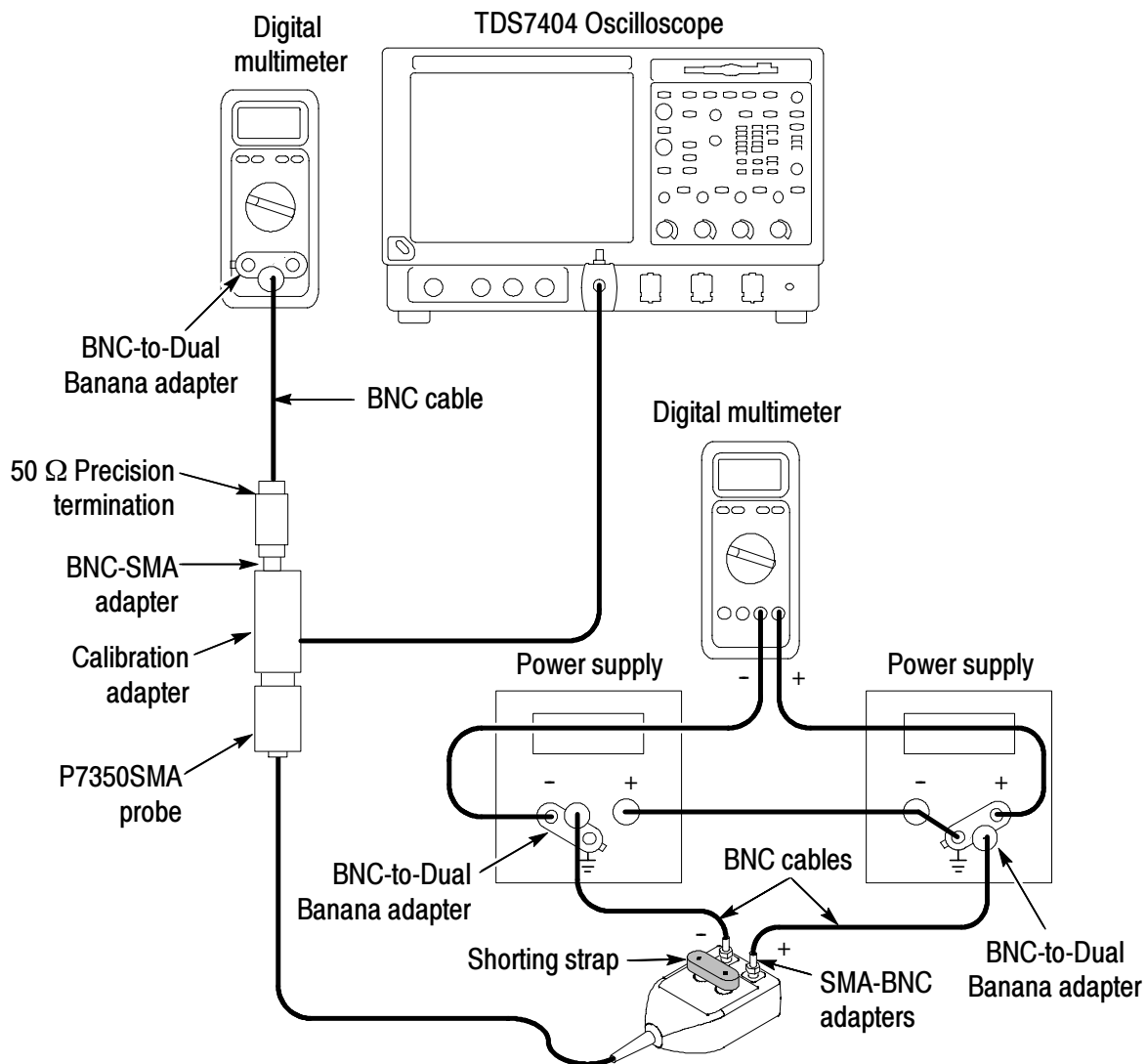

Figure 29: DC Gain Accuracy setup

3. Record the output voltage (on the second DMM) as V_{out1} .
4. Disconnect the BNC-to-dual banana plug adapters from the power supplies. Leave the DMM leads connected to the adapters.
5. Connect the BNC-to-dual banana plug adapters into the opposite power supplies to reverse the voltage polarity to the probe inputs. See Figure 30.
6. Record the actual source voltage (now a negative value), as V_{in2} .

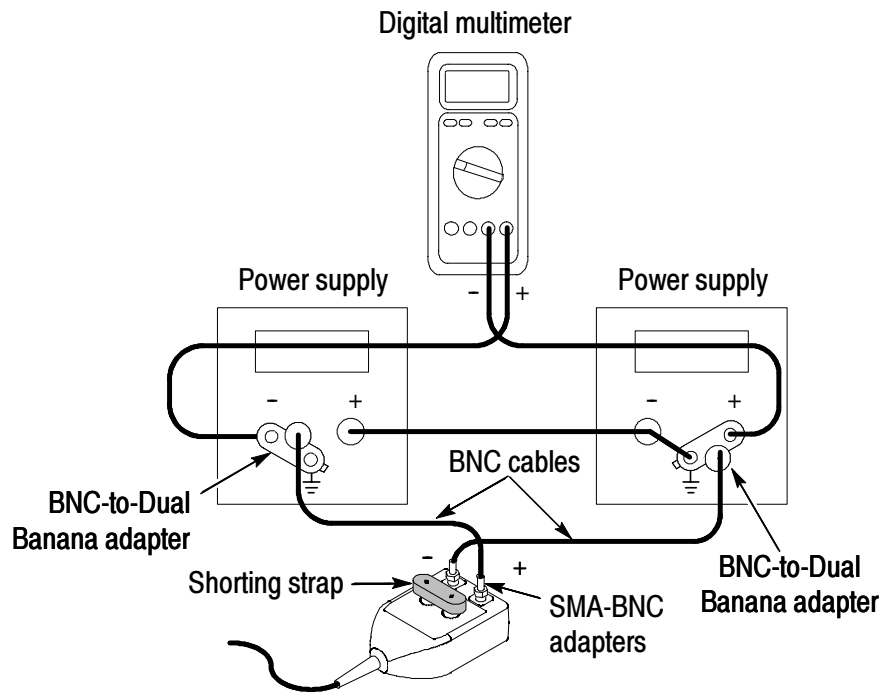

Figure 30: Reverse the power supply polarity on the probe inputs

7. Record the output voltage (on the second DMM) as V_{out2} .
8. Calculate the gain as follows: $(V_{out1} - V_{out2}) \div (V_{in1} - V_{in2})$.
9. Verify that the gain is 0.16, $\pm 2\%$.
10. Record the calculated gain on the test record.

Rise Time

This procedure verifies that the probe meets the differential rise time specification. Two rise times are measured; the test system alone, and the test system with the probe included. The probe rise time is calculated using the two measurements.

This test uses the TDR function of the 80E04 sampling head as a fast rise time signal source. A second 80E0X sampling head is used to take the measurements. Although the following procedure assigns the TDR and measurement functions to specific oscilloscope channels, any channels can be used. However, the TDR function is only available on 80E04 sampling heads.

1. Remove the probe from the test setup.
2. Connect the test equipment as shown in Figure 31 on page 61. Connect the TekConnect-to-SMA adapter to Channel 8.



CAUTION. *To prevent mechanical strain on the connectors, use care when working with SMA connectors: Support equipment and use a torque wrench to tighten connections to 7 in-lbs.*

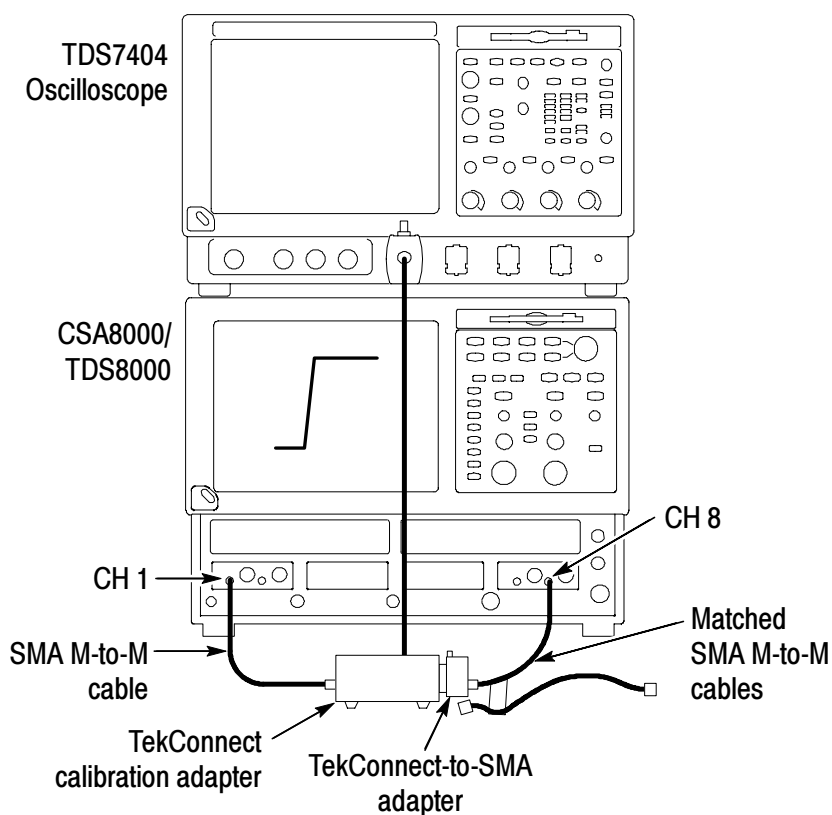

Figure 31: Test system rise time setup

NOTE. The CSA/TDS8000 oscilloscope is used for taking the measurements in these procedures. All references to oscilloscope adjustments refer to the CSA/TDS8000. The TDS7404 oscilloscope is only used to power the probe.

3. Turn on Channel 1 and set the vertical scale to 50 mV/div.
4. Set the Channel 7/8 sampling head to TDR mode:
Press the **SETUP DIALOGS** button and select the **TDR** tab.
See Figure 32 on page 62.

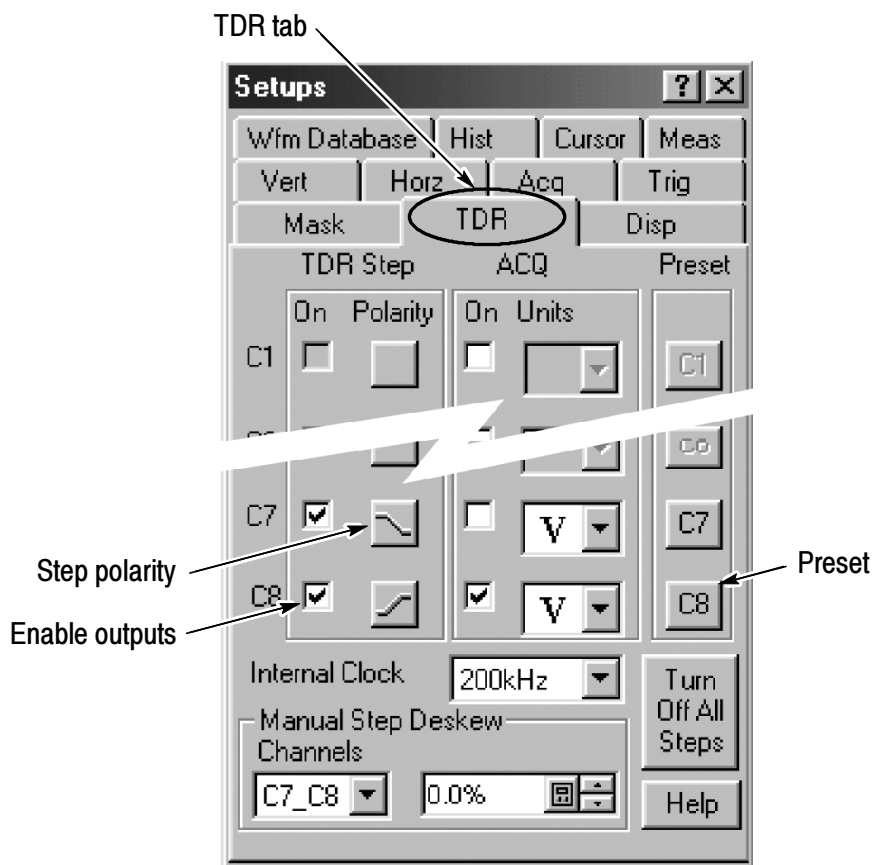

Figure 32: Setting the TDR parameters

5. Set the Channel 7 (C7) **Polarity** to negative (falling).
6. Set the Channel 8 (C8) **Polarity** to positive (rising).
7. Set the **Preset** of Channel 7 and 8 on.

TDR Preset sets Internal Clock in the Trigger menu, turns on the TDR Step in the TDR Setups menu, turns on the channel and selects the acquisition Units in the TDR Setups menu, and sets the horizontal scale, position, and reference.

The sampling module will turn on a red light next to the SELECT channel button, indicating that TDR is activated for that channel.

8. Turn off the display for Channel 7 and 8 so that only Channel 1 is shown on screen.

- 9.** Adjust the oscilloscope horizontal and vertical position controls to display a signal similar to that shown in Figure 31.
- 10.** Set the oscilloscope horizontal scale to 50 ps/div and center the waveform.
- 11.** Use the oscilloscope measurement capability to display rise time. Increase the stability of the pulse edge measurement by using averaging, if available. Rise time is determined from the 10% and 90% amplitude points on the waveform. Record the rise time as t_s .

The following steps instruct you to assemble the test setup that includes the probe, as shown in Figure 33 on page 64. The system and probe rise time (t_{s+p}) that you measure in step 18 is used to calculate the probe rise time (t_p) in step 19.

- 12.** Remove the TekConnect-SMA adapter from the test setup.
- 13.** Connect the probe to the TekConnect calibration adapter.
- 14.** Connect the matched SMA cables to the probe SMA inputs and the sampling head (Channels 7 and 8).

The test setup should now be connected as shown in Figure 33 on page 64.

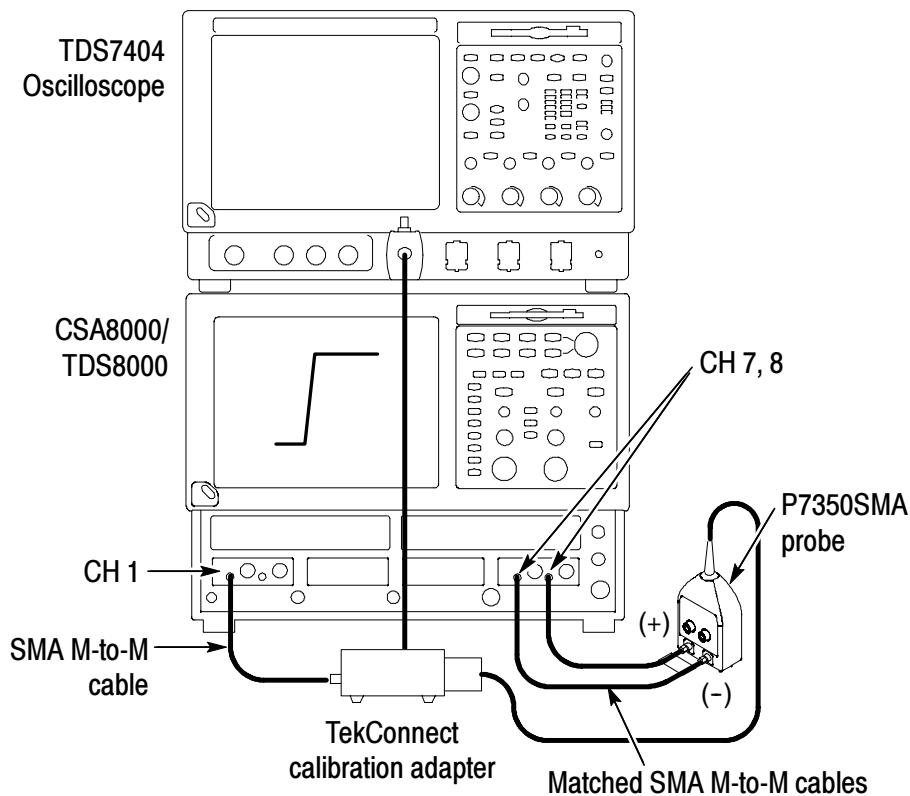

Figure 33: Test system rise time setup with probe

15. Expand the horizontal scale to help locate the step edge, then adjust horizontal range to 500 ps/div while maintaining the edge view. For a more stable measurement display, turn averaging on.
16. Adjust the oscilloscope vertical scale to 20 mV/div, averaging on.
17. Adjust the horizontal positioning to place the rising edge of the signal on the second vertical and center horizontal graticule lines.
18. Use the oscilloscope measurement capability to display rise time. Rise time is determined from the 10% and 90% amplitude points on the waveform. Record the rise time as t_{s+p} .

19. Calculate the probe rise time using the following formula:

$$t_p = \sqrt{t_{(s+p)}^2 - t_s^2}$$

20. Record the calculated probe rise time on the test record.

Test record

Probe Model: _____

Serial Number: _____

Certificate Number: _____

Temperature: _____

RH %: _____

Date of Calibration: _____

Technician: _____

Performance test	Minimum	Incoming	Outgoing	Maximum
Differential mode input resistance	98 Ω			102 Ω
Output offset zero	- 10 mV			+ 10 mV
DC gain accuracy	0.1568			0.1632
Differential rise time	N/A			100 ps

Appendix C: Maintenance

This section details the maintenance for the P7350SMA differential probe.

Inspection and Cleaning

Protect the probe from adverse weather conditions. The probe is not waterproof.



CAUTION. *To prevent damage to the probe, do not expose it to sprays, liquids, or solvents. Do not use chemical cleaning agents; they may damage the probe. Avoid using chemicals that contain benzene, benzene, toluene, xylene, acetone, or similar solvents.*

Clean the exterior surfaces of the probe with a dry, lint-free cloth or a soft-bristle brush. If dirt remains, use a soft cloth or swab dampened with a 75% isopropyl alcohol solution. A swab is useful for cleaning narrow spaces on the probe. Do not use abrasive compounds on any part of the probe.



CAUTION. *To prevent damage to the probe, avoid getting moisture inside the probe during exterior cleaning, and use only enough solution to dampen the swab or cloth. Use a 75% isopropyl alcohol solution as a cleanser, and rinse with deionized water.*

Replacement Parts

Refer to the *Replaceable Parts* section for a list of customer replacement parts. Due to the sophisticated design of the P7350SMA differential probe, there are no user replaceable parts within the probe.

Preparation for Shipment

If the original packaging is unfit for use or not available, use the following packaging guidelines:

1. Use a corrugated cardboard shipping carton having inside dimensions at least one inch greater than the probe dimensions. The box should have a carton test strength of at least 200 pounds.
2. Put the probe into an antistatic bag or wrap to protect it from dampness.
3. Place the probe into the box and stabilize it with light packing material.
4. Seal the carton with shipping tape.

Appendix D: Replaceable Parts

This section contains a list of replaceable parts for the P7350SMA differential probe. Use this list to identify and order replacement parts.

Parts Ordering Information

Replacement parts are available from or through your local Tektronix, Inc. service center or representative.

Changes to Tektronix instruments are sometimes made to accommodate improved components as they become available and to give you the benefit of the latest circuit improvements. Therefore, when ordering parts, it is important to include the following information in your order:

- Part number
- Instrument type or model number
- Instrument serial number
- Instrument modification number, if applicable

If a part you order has been replaced with a different or improved part, your local Tektronix service center or representative will contact you concerning any change in the part number.

Using the Replaceable Parts List

The tabular information in the Replaceable Parts List is arranged for quick retrieval. Understanding the structure and features of the list will help you find the information you need for ordering replacement parts.

Item Names

In the Replaceable Parts List, an Item Name is separated from the description by a colon (:). Because of space limitations, an Item Name may sometimes appear as incomplete. For further Item Name identification, U.S. Federal Cataloging Handbook H6-1 can be used where possible.

Indentation System

This parts list is indented to show the relationship between items. The following example is of the indentation system used in the Description column:

<i>1</i>	<i>2</i>	<i>3</i>	<i>4</i>	<i>5</i>	<i>Name & Description</i>
					<i>Assembly and/or Component</i>
					<i>Attaching parts for Assembly and/or Component</i>
					<i>(END ATTACHING PARTS)</i>
					<i>Detail Part of Assembly and/or Component</i>
					<i>Attaching parts for Detail Part</i>
					<i>(END ATTACHING PARTS)</i>
					<i>Parts of Detail Part</i>
					<i>Attaching parts for Parts of Detail Part</i>
					<i>(END ATTACHING PARTS)</i>

Attaching parts always appear at the same indentation as the item it mounts, while the detail parts are indented to the right. Indented items are part of, and included with, the next higher indentation. Attaching parts must be purchased separately, unless otherwise specified.

Abbreviations

Abbreviations conform to American National Standards Institute (ANSI) standard Y1.1

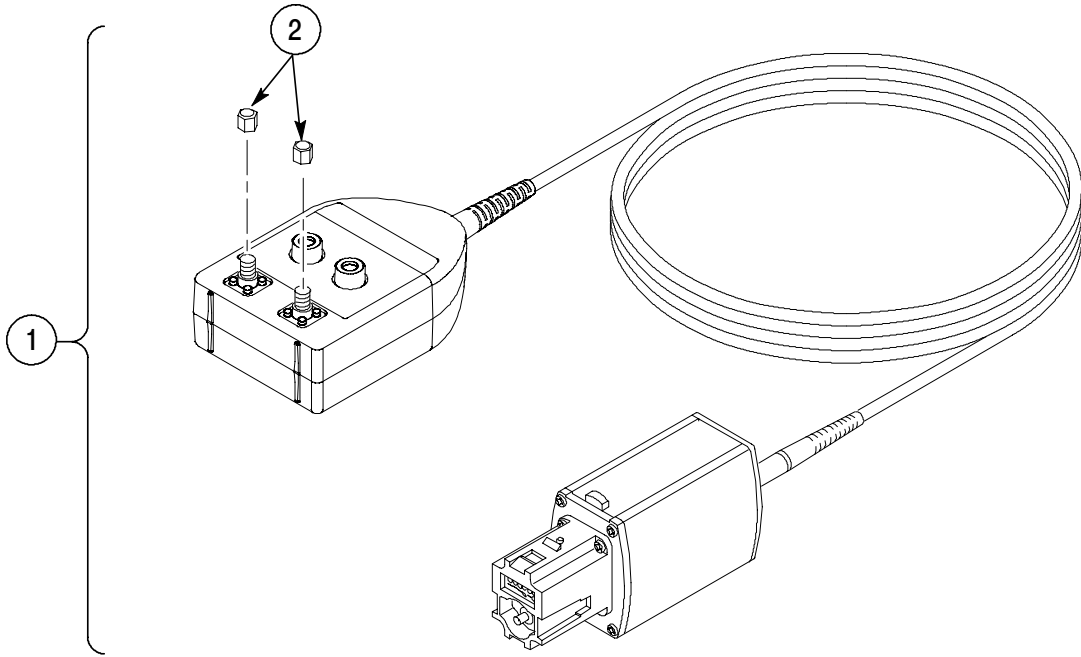

Figure 34: Replaceable parts

Fig. & index no.	Tektronix part no.	Serial no. Effective	Dscont	Qty	12345 name & description	Mfr. code	Mfr. part no.
34-1	P7350SMA			1	PROBE, P7350SMA	80009	P7350SMA
2	015-1022-01			2	TERMINATION, 50 OHM, SMA	060D9	015-1022-01

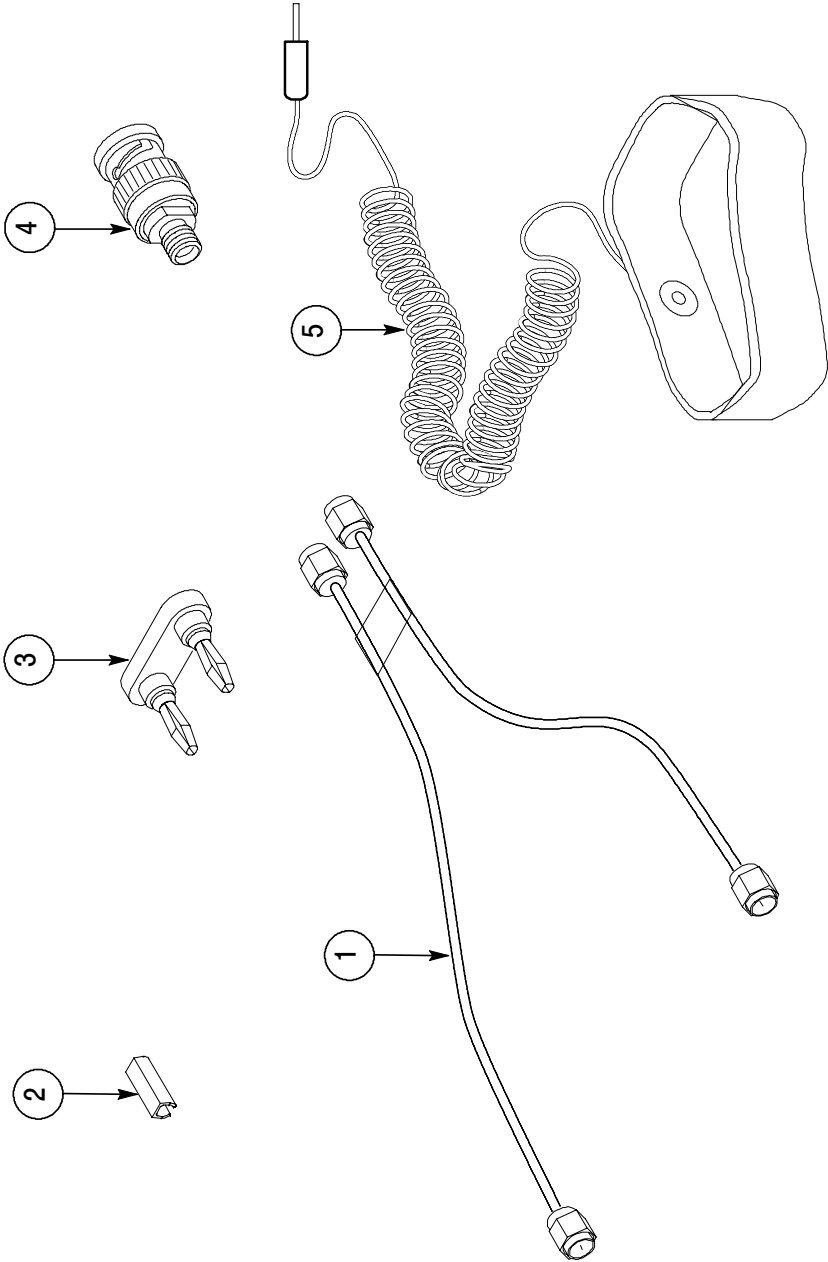

Figure 35: Standard accessories

Fig. & index no.	Tektronix part no.	Serial no. Effective	Dscont	Qty	12345 name & description	Mfr. code	Mfr. part no.
STANDARD ACCESSORIES							
35-1	174-4866-XX			1	CABLE ASSY,DUAL SMA;12"L,MATCHED DELAY	060D9	174-4866-XX
-2	016-1886-XX			1	MARKER KIT,ID:CABLE MARKER BAND,2 EA, VAR COLRS	80009	016-1886-XX
-3	012-1667-XX			1	ADAPTER,BANANA;ENCAPSULATED DOUBLE PLUG SHORTING BAR	80009	012-1667-XX
-4	015-0572-XX			1	ADAPTER,CONN; SMA FEMALE TO BNC MALE	80009	015-0572-XX
-5	006-3415-XX			1	STRAP,WRIST:3M TYPE 2214, ADJUSTABLE,6 FT COILED CORD	TK0623	RTI 8454001829
	071-1264-XX			1	MANUAL,TECH:INSTRUCTION,P7350SMA	80009	071-1264-XX

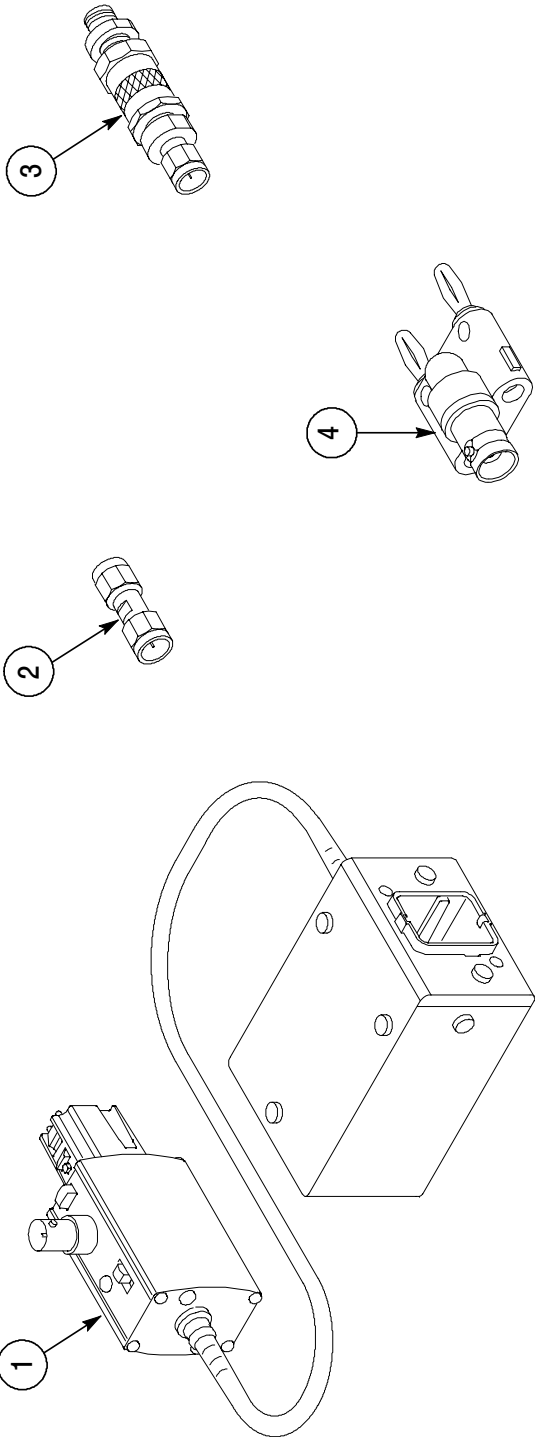

Figure 36: Optional accessories

Fig. & index no.	Tektronix part no.	Serial no.		Qty	12345 name & description	Mfr. code	Mfr. part no.
		Effective	Dscont				
OPTIONAL ACCESSORIES							
36	-1	067-0422-XX		1	CALIBRATION FIXTURE ASSY:ECB TO TOP,P7000 SERIES	80009	067-0422-XX
	-2	015-1011-XX		1	CONN,ADAPTER;SMA, MALE TO MALE, STAINLESS STEEL/GOLD	80009	015-1011-XX
	-3	015-0708-XX		1	ADAPTER,SMA PHASE ADJUSTER;18 GHZ, SMA MALE TO SMA FEMALE,RANGE>25PS	80009	015-0708-XX
	-4	103-0090-XX		1	ADAPTER,CONN; BNC FEMALE TO DUAL BANANA PLUG	80009	103-0090-XX

CROSS INDEX - MFR. CODE NUMBER TO MANUFACTURER

Mfr. code	Manufacturer	Address	City, state, zip code
060D9	TENSOLITE CORPORATION	3000 COLUMBIA HOUSE BLVD, SUITE 120	VANCOUVER, WA 98661
80009	TEKTRONIX INC	14150 SW KARL BRAUN DR PO BOX 500	BEAVERTON, OR 97077-0001
TK0623	GENERAL TOOL & SUPPLY CO	2705 NW NICOLAI ST	PORTLAND, OR 97210